

## Designing Super-Regenerative Receivers

By Dr Eddie Insam

Copyright (c) 2001 Copyright© 2002 Eddy Insam - email: edinsam@eix.co.uk

Published In Electronics World: April 2002

Printed Copies of this article can be obtained from Electronics World. Anne Boleyn House. 9-13 Ewell Road, Cheam Surrey SM3 8BZ UK

No part can be copied without the express authority from the author

### ABSTRACT BOX

Super-Regenerative radio designs have been around for well over 60 years, and hundreds of circuits have been published, usually with little or no description on how they work. Eddy Insam dispels the magic and explains the details

A few years ago, I was doing a short project for a cell phone manufacturer. During lunch break, a number of their RF engineers were sitting around the table looking at a piece of paper with a little circuit drawn on it. "How does it work?" they asked me. It was obviously a super-regenerative receiver, it said so underneath. It had one transistor, a few resistors, and some capacitors. "All this RF expertise, and none of you know how this works?" I said, saving myself from giving a direct answer, as I looked for the door.

Some of us have a box in the back of our minds where we put all those concepts we do not understand or can figure out how they function. We label this box "things that work by black magic." This circuit was certainly in there somewhere.

I decided I would find out how it worked. After all, the circuit only had one transistor.

It can't be that difficult to crack, or can it? . Soon, I found that most of the articles and manufacturer's literature I looked at were particularly short in theoretical descriptions, "adjust R4 for best sensitivity." was the best I could get. I had to go quite a way back in time to find any publications that covered the subject in detail. I was also surprised to find how little had been published since then.

Nowadays, with so many alternative solutions available, super-regenerative radios appear to be outmoded and irrelevant. On the plus side, the concept has virtues; the radios are simple and consume little power. An understanding of how they work may widen their applications into new areas. I would not be surprised if they make a come back every so often under different guises, especially as new components such as stable hi-Q resonators are developed.

---

### The theory

One always gets a good feeling when the operation of an intricate physical process is made clearer by the use of simple maths. Equivalent circuits are a good case in point. Look at the circuit in **Fig1**. This describes the very basic operation of a super-regenerative receiver.

Fig 1 (fig1.ai)

Switching a negative resistance across an LC tank circuit causes positive exponential self-oscillations to be generated at its natural resonant frequency. The startup time is a function of initial conditions, namely the tiny RF currents induced in the coil from an aerial. The resulting wave growth can be easily measured by external circuitry. The negative resistance is generated by the active component used: transistor, FET, or other.

The circuit is a simple **LC** tank that includes a conductance **G** representing all the resistive losses in the circuit. I shall be using conductances rather than resistances as it simplifies the maths and the final analysis. To all extents, **G=1/R**, where **R** is the loss resistance.

A small RF source **i(t)** is also shown in parallel with the coil. This represents the external RF radiation that is somehow induced into the tank, maybe directly with the coil acting as an aerial, or coupled from an RF amplifier (not shown). Just assume for the moment that this signal has very small amplitude, and has a frequency similar to that of the self-resonance frequency of the tank:

Eq 1

Before  $t=0$ , the switch is in the off position. The only voltage across the tank is that resulting from the RF excitation. I am calling this quiescent voltage **V<sub>o</sub>**, which is basically **V<sub>o</sub>=i(t)/G** at resonance. So far, so good.

The interesting bit happens when the switch is closed. At this point an extra conductance is added across the tank, and the total resistive load is now the sum of the quiescent conductance **G** plus the new conductance just switched in. To simplify the analysis, I shall replace the two conductances by a single one that switches its value from **G** at time  $t<0$ , to a new value **-g** at  $t\geq 0$ . Notice that this new conductance is negative. In other words, at time  $t=0$  and beyond, the **LC** tank has a negative conductance **-g** applied across it. You cannot buy negative resistors at the shops. However, a negative resistance can be emulated with an active component, such as a transistor or FET. More on this later.

The corresponding equation for the circuit is:

Eq2

And the solution, in terms of the resulting voltage across the tank, is of the general form:

Eq3

Note the positive sign in the exponential. The output is an exponentially rising, high frequency oscillation. **Fig 1** shows the shape.

Mathematical types will immediately notice that such an output requires non-zero initial conditions. This is provided in our circuit by the minute RF excitation. If the input RF signal had zero amplitude, there would be no drive, and the circuit would take an infinite time to start oscillating. This is not really an option. In practice, small disturbances such as thermal noise are enough to start the oscillations.

One peculiar characteristic about exponential waveforms is that two similar functions of different amplitudes look like the same two functions but time delayed. **Fig 2a** shows the effect where two input signals of different amplitudes  **$e_1(t)$**  and  **$e_2(t)$** , are shown as apparent time delayed versions of each other. This time delay is a logarithmic function of the ratio of amplitudes, i.e.:

Eq 4

Fig2(fig2.ai)

Differences in input RF levels cause the rising oscillations to take different times to reach a given amplitude level (2a). A comparator can be used to time these differences and generate pulse widths proportional to the logarithm of the input RF amplitude (2b). The repetition rate of this process can be controlled by an external timer, or internally by wiring

the comparator to re-trigger the system on completion (2c). The pulse width information can then be low pass filtered to recover the modulated audio or data.

What this means is that, no matter how small our input RF signal  $V_o$  is, sooner or later there will be a corresponding exponentially rising waveform generated across the coil. This waveform will always have the same "shape" and amplitude, but its "rise time" or delay, if we could define such a term, will vary, and will be dependent on the amplitude of our minute source signal  $V_o$ .

Left to themselves, the oscillations would carry on increasing in amplitude forever. In practice they will level out as nonlinearities in the associated circuits come into effect. The system then becomes a steady oscillator. We are not interested in this however. We are only concerned about detecting the time between the switch closure and the time at which the self-oscillations rise to a specific level or threshold. Measure these times, and we have a radio receiver. **Fig 2b** shows the principle.

One very important point is worth noting: The input RF excitation provides the starting conditions at time  $t=0$  and thereabouts. The input signal plays no part in the process much before, or after this time. In other words, this is a RF sampled data system.

Another important fact is that the resulting self-oscillations are at the natural frequency of the **LC** tank as given by **Eq 2**, and not at the frequency of the input RF signal.

---

## The Detector

How does all this translate into radio receiver designs? Going back to **Fig2b**, we can see the principles of a possible detector scheme. A voltage level comparator senses voltage

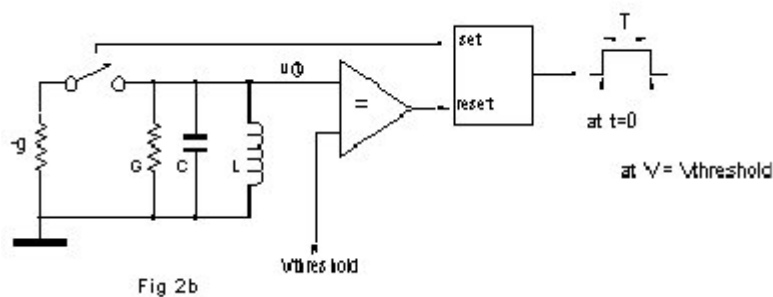

peaks across the coil. The detector triggers when the first peak reaches some fixed threshold. The actual value is not too important, as long as it occurs before saturation.

At time  $t=0$ , a latch flip-flop is set at the same time the switch is closed. Some time later, the comparator resets the latch when the first positive cycle of  $v(t)$  hits the threshold. We then take the pulse width generated by the latch. The general relationship between this width and the original RF input amplitude  $V_0$  is:

Eq5

That is, the resulting width is proportional to the logarithm of the input signal amplitude. In other words, linear microvolts are converted to log milliseconds. This logarithmic response is what gives super regenerators their intrinsic AGC (Automatic Gain Control) behaviour.

One thing may not be very clear at this point. Our detector is a "once only" device. It takes one sample of the input RF signal, generates a single pulse width, and then it stops. In order to detect more samples, we must open the switch, allow the oscillations across the tank to settle or decay to zero, and then re-start the operation by closing the switch again. The process is then repeated forever.

### Quenching

This is the traditional name given to the process of stopping and restarting the detector after each sample. It comes from the fact that the **LC** tank needs to be "quenched" or stopped of oscillations after it has reached full swing. Quenching rate is another word for sampling rate.

When the switch is opened, the self-oscillations remaining across the tank will start to decay. The decay rate will be given by the original components in **Fig 1**, that is:

Eq6

Note that the conductance is now **G**, the original quiescent loss resistance of the tank, and not our negative add-on **-g**, which has now been disconnected. We must allow this waveform to decay to as near zero as possible, and to less than the expected input RF signal level. If this not the case, the receiver may sample remainder signals from previous oscillations in preference to our wanted RF input, reducing the sensitivity.

This decay can take a considerable time, especially in low loss tank circuits. This places a limit in the repetition sampling rate at which we can operate the receiver.

Going back to our detector of **Fig 2b**, a simple way to provide quenching is by driving the switch on and off using an external, fixed rate, repetitive signal. The repetition rate of this external source must be low enough to allow sampling, and also to allow for full discharge of the **LC** tank. The final output from the detector will be a fixed rate, variable pulse width modulated (PWM) signal. This method is traditionally known as external quenching.

The advantages of external quenching are that it is easy to implement, and produces predictable results. The disadvantages are that a large part of the pulse width cycle is wasted, resulting in low conversion gain when decoding pulse widths into analogue signals.

An alternative solution is one where the sampling is restarted as soon as the pulse width terminates. That is, we make the end of the detection pulse activate the next start. This is known as self-quenching. **Fig2c** shows the concept. The falling edge of the comparator's output triggers a monostable that produces a pulse wide enough to discharge the **LC** tank, and is used to re-set the switch. The detector output is now a pulse train of variable width and variable frequency. No external repetitive source is required, as the circuit will self trigger. Self-quenching generally produces higher conversion pulse width recovery rates.

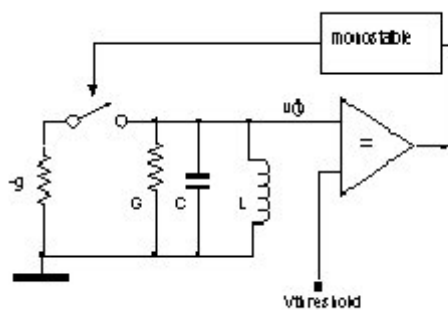

Fig 2 c

### Quench Rate

Like any sampled data system, the quench or sample rate will place a limit on the recovered bandwidth (do not confuse this with radio selectivity). This rate must be at least twice that of the wanted recovered bandwidth. For example, for audio work, quench rate should be at least 10kHz.

The quench cycle has three parts (see **Fig 4a**): RF rise, RF decay, and the device's relaxation time, which overlaps it. The RF rise is due to the effect of the negative resistance during sampling. The RF decay is the time taken for the tank to drain its oscillations, and the relaxation time is the time taken for the circuit itself to "recover". The minimum value for the quench rate is bound by the rise and decay times of oscillations in the tank circuit. It helps to visualise these quench times by relating the figures to the Q or merit figure of the circuits as follows:

Eq7

Later on, I shall mention that best performance is achieved when the negative conductance is kept as low as possible around  $t=0$ . However, this would make  $T1$  in the equation above too large. A design compromise calls for a circuit in which  $g$  is kept very low at the start, but somehow is sharply increased in value after this time. Remember that the receiver sampling action only occurs around  $t=0$ .

Also, note that  $T2$  is required to be much greater than the natural Q of the quiescent tank. We want the remaining self-oscillations built up in the tank to drop to as near zero as possible (the definition of Q is associated with a drop of only  $1/e$  of amplitude). This is the main reason why it is difficult to use high Q devices such as quartz crystals in super-regenerative receivers. For example, a 30Mhz crystal may place a quench rate limit of less than 400Hz.

---



## Self Quenching in Practice

One of the reasons why super-regenerative receivers were so popular in the past was that a single device, e.g. valve or transistor, could be used to perform detection and self-quenching all in one, and at the same time, thus saving on components.

The principle of self-quenching in active devices is based on the relaxation principle. The two operations: self-oscillation and self-quenching, are also linked. The active device behaves as a nonlinear negative resistance device, converting DC power into AC power, stored as dynamic energy within the **LC** tank. The circuit is designed so that, as energy in the **LC** tank is "absorbed" and the wave amplitude increases, the average DC quiescent operating point of the active device shifts. Most active devices only support negative resistance over a short operating range. Therefore, as the DC operating point shifts, there comes a point at which the active device cannot provide any more negative resistance. A normal oscillator will settle just below this operating point and provide constant oscillations. A relaxation system cannot, because it will have extra components added to prevent this. When the limit operating point is reached, the active device will "starve" and oscillations will just stop. The only option left is to discharge the circuit to its original DC conditions before starting all over again.

A common super-regenerative design uses the rising self-oscillation peaks to pump-charge a capacitor, taking advantage of some diode-like nonlinearity such as the base emitter junction of a transistor. This charging results in the increase of some related dc parameter such as base bias. During build-up, the RF cycle peaks are always higher and higher, causing conduction of the transistor on the tip of every further cycle, and ahead of the rising DC bias, resulting in a form of pumped Class C device. At some point, e.g. collector saturation, the rate of rise will flatten, causing no more pumping cycles, leaving the transistor heavily negatively biased, and therefore switched off. The transistor can now only wait for the bias capacitor to discharge slowly, before it resumes conduction, allowing the cycle to start all over again. Most of the cunning designs seen in super-regenerative receivers mainly relate to methods and techniques for self-quenching using the least of components. As I shall be mentioning later, there is usually a clash between circuit simplicity and ideal design objectives.

## Time Varying Conductance

In my simple analysis of **Fig 1**, I have assumed that the negative conductance is applied suddenly. In practice, this is not the case. A transistor, coming into active mode will present a load that varies with time. In other words, **g** is really a function of time **g(t)**. We need to rewrite **Eq 2** as.

Eq 8

The solution of this equation is a bit more complex, so I am going to make some assumptions. We are only interested in what happens at around  $t=0$ . We can also assume that  $\mathbf{g(t)}$  is a simple function of time, e.g. a linear slope, and that the input RF signal is a short duration burst at around  $t=0$ . A simplified solution for the resulting waveform at time T, where T is a short time after  $t=0$  is: (compare this with **Eq3**)

Eq 9

Some extra terms should be included because the RF input signal is present during the whole of the time. A more comprehensive result is as follows (still not including all the terms!):

Eq 10

The significance of some of these terms will be covered in the following sections.

### **Comments on Sensitivity**

It may be a good idea to start by defining what we mean by sensitivity. Normally, this is the signal level a receiver must have at its input, in order to generate an output which can be recorded as a signal to noise ratio (or signal+noise to noise ratio). In practical terms, this is determined by total gain, and by the various sources of noise that impart a floor to performance. In a super-regenerative receiver, the "instant" sensitivity goes through a maximum value at  $t=0$ , and falls off rapidly on each side. It is primarily a function of the negative conductance and its slope at this point. During this time, the receiver has a very large gain (you can work this out from **Eq 2 and 3**). So large in fact, that noise level is the only limiting factor. You will recall that self-oscillations are always generated, no matter how small the initial conditions, whether from a RF signal or from noise.

The main source of noise comes from the active component. A transistor operating as a negative resistance generator can be a very noisy device. A main design objective is to employ a circuit that generates the minimum amount of noise. I am not going to cover details on how to design low noise oscillators, only to say that this is a very important design consideration regarding sensitivity. The literature at the end of this article contains some further information on this.

A number of other factors also contribute to sensitivity. Firstly, there is the necessity to couple the RF signal into the tank coil with the minimum

of loss. In order to avoid radiation, we do not want to connect an aerial directly into the tank. We may prefer to use a separate RF amplifier. The RF amplifier does not need to have much gain, only enough to improve the signal to noise ratio and to provide for some RF isolation. As an aside, and to conserve power, the RF amplifier only needs to be powered during sampling time.

Secondly, there is the efficiency of the detector in converting the pulsed modulated train to useable analogue voltages. I have already covered the marginal advantages that self-quenching can provide. To maximise conversion, the PWM detector must have a wide dynamic range of mark to space ratios to RF input levels. By means of an example, I shall be discussing in the next section how design choices in this area can have a large effect on performance.

Thirdly, a super-regenerative receiver can be made as sensitive as the noise floor level of the device will allow. It may appear that it can be as sensitive as one wants it to be. The fact is that a super regenerator does not "capture" the entire incoming signal, but only samples a small part of it. i.e. the input RF signal is sampled for a very short time, whereas in a normal receiver the input signal is available all the time, and forms constructively in the tune circuit.

Lastly, and because of the logarithmic performance nature of super-regenerative receivers, a small signal will produce about the same quieting levels as a loud one. A plot of S/N ratio against signal input will show a much flattened curve. This can make the "perceived" sensitivity much less than it really is.

### **And Bandwidth**

Bandwidth can be nominally defined as the corner frequency points at which some useful response (i.e. a signal level, or sound out from a loudspeaker) drops by a certain value, usually 3db.

In the case of an instantly switched, fixed value conductance **g**, the equivalent circuit for bandwidth calculation purposes is just that of a **LC** tuned circuit in parallel with the total conductance:

Eq 11

A more relevant situation is of course, when the conductance varies with time. One term from **Eq 10** will give us the selectivity factor:

Eq 12

The resulting frequency response "shape" is rounded, and not too different from a gaussian bell curve. We can derive a measure for bandwidth:

Eq 13

This bandwidth is specified at one neper down (approx 8.7db). Note the dependence of bandwidth on conductance slope at  $t=0$ . This bandwidth is quite narrower than that defined in **Eq 11**.

In order to maximise bandwidth, a design goal is to make the conductance slope as shallow as possible at  $t=0$ . We have some control over slope by adjusting the loop gain of the oscillator. Circuits with low loop gains produce shallow slopes; circuits with high loop gains produce sharp slopes. Unfortunately with simple transistor circuits, it is not always possible to arrange for them to perform the way we want, so compromises will be necessary.

Lastly, I should say that the above analysis does not fully answer the bandwidth question. Super-regenerative receivers have a logarithmic amplitude response, and the arguments above should only apply to very low level signals. At higher RF input levels, the bandwidth response will be flattened, and the perceived bandwidth will be much wider.

### **The Features**

I am not going to say "problems" as this is not a fashionable word to use when talking about properties that do not work in our favour. I shall be positive, and refer to them as interesting challenges.

**RF Radiation.** The situation is simple: an aerial directly connected to our **LC** tank will radiate. This is because during those short moments after sampling where the self-oscillations build up, the tank has considerable RF energy, which will escape up into the aerial. In other words, the receiver is also a pulsed RF transmitter with narrow bursts of RF modulated at the quench repetition frequency. The radiated frequency spectrum will be spread over a bandwidth around  $\omega$  and at twice the quench frequency. An obvious way to minimise radiation is to use a separate RF amplifier. Another effective way of capping the problem is to keep oscillation amplitudes and power consumption to a minimum. Most transistors will work quite happily with only microamps of current. Using higher quench frequencies, and keeping the oscillation bursts very narrow also helps.

**Lack of frequency stability.** Simple designs normally use single LC coils with inherent limitations of mechanical construction and manufacturing spreads. Stability can be sharply improved by using crystals, ceramic resonators, SAW or mechanical resonators.

**Circuit stability.** This is the most difficult design topic to address. Ideal super-regenerator performance requires critical negative conductances requirements. This cannot be met by simple one transistor circuits using

production spread components such as resistors and capacitors. In practice, circuits need to be individually tweaked or adjusted during manufacture for the right bias conditions. One possible solution is to use substrate level negative resistance generators (e.g. gyrators), that can be accurately controlled and programmed.

---

### **And now, some practical circuits**

The circuit in **Fig 3** is typical. This is an otherwise standard feedback oscillator that has been modified for self-quenching by the addition of **L2**, **R1** and **C2**.

*Fig3 (fig3.ai)*

A typical receiver layout. This is nothing more than a simple oscillator with extra components added (L2, R1, C2) to induce self quenching. Post detector circuits are shown in 3b and 3c. Although similar in appearance, the two post detectors behave very differently. See text.

**Here is how it works:** The base voltage is fixed at some value, around 2 volts in this case; and because of the decoupling capacitor, at ground potential for AC purposes (ignore **C6** for the moment). Lets start at time point **t1** in **Fig 4a** where collector self-oscillations have just started and are increasing exponentially with time. The RF voltage at the emitter is derived from this via capacitor voltage divider **C3**, **C4**. The clamping effect of the base-emitter junction also causes the DC average at the emitter to rise with time, resulting in the compound waveform shown in **Fig 4b**. The transistor conducts only for a short time at the very peak of every negative cycle. This causes the pumping action at the collector, which in turn energises the **LC** tank with ever rising oscillations. Note that the waveform at **Fig 4c** is just a "filtered" version of **Fig 4b** at the "cold" end of **L2**, and that **Fig 4b - Fig 4c = Fig 4a**.

Fig4 (fig4.ai)

Self quenching action for the circuit in Fig3. (a) is the voltage at the collector, (b) at the emitter, and (c) at the R1/C2 junction. The horizontal dotted line represents the threshold voltage below which the transistor comes into conduction (about 1.4v). During conduction, i.e. between t1 and t2, the transistor operates in class C, building up a charge that eventually causes the transistor to switch off suddenly at t2. A slow discharge via R1/C2 allows oscillations to start again at t4.

These self-oscillations cannot carry on rising forever. At some point, **t2** in **Fig 4a**, the negative swings will cause the collector voltage to go below the base voltage causing the transistor to conduct in the reverse direction. In a normal oscillator, this would cause signal into the emitter to be reduced, causing less collector current to flow, and making the whole system settle into a fixed amplitude level oscillator. However, the inclusion of **R2** and **C3** changes this drastically. At the instant the collector oscillations start to clamp or level off at **t2**, the base emitter junction stops conducting. This starts the stalling effect. The higher than normal DC voltage at the emitter (about 3 volts in our circuit) ensures the transistor remains off from then on, and the oscillations stop completely. The transistor will remain completely switched off, and now can only wait for **R1C2** to discharge, between **t2** and **t4** in **Fig 4a**. This discharge has to go down to the base voltage minus .6 volts to re-start conduction, i.e. to about 1.4 volts in our circuit. As RF is fed from the collector to the emitter, the DC average at the emitter is slowly charging to ever increasing levels. The transistor only conducts because each oscillation pulse cycle is always slightly larger than the previous, and enough to bring the emitter into conduction, slightly ahead of the DC rising level. This is between **t1** and **t2** in **Fig 4a**.

Note that when the transistor switches off, the RF self-oscillations accumulated in the tank will also start to decay in their own time, this is between **t2t3** in **Fig 4a**. This time is much less than the relaxation discharge

of the transistor, allowing the tank to discharge fully.

The real action happens now when the transistor begins to conduct again. This is now equivalent to  $t=0$  in **Fig 1**. At **t4** in **Fig 4a** (effectively the same as **t1**, as this is a forever repeating cycle), the transistor slowly comes into conduction. As it comes into conduction, it starts presenting a negative resistance to the tank. Self-oscillations will now start at a time depending on the tiny amount of signal RF present in the coil. You can see this on an oscilloscope connected to **R1**. The time difference between **t1** and **t4** will be seen to vary depending on input signal level.

What do the components do? The base biasing resistor and decoupling capacitor are only there to provide a fixed bias (I shall come to **C6** later on). Anything from 1.5 to 3 volts will do. Adjusting the base voltage is a convenient way of controlling quench rate, so you can replace the resistors with a 100k trim pot divider for development purposes. **C3** and **C4** form a voltage divider to feed back a proportion of the collector signal back to the emitter. The values are more or less the same as would be used for an oscillator at the same frequency, but tweaked to keep loop gain as small as possible, consistent with reliable starts. We want to make **C3** as small as possible, 2-10pf are common values for the 30-200MHz range. For the same reason, **C4** should be made as high as we can, and 30-50pf values are common. **R1** and **C2** determine the quench rate which is given very approximately by  $t=0.5R1C2$ . **R1** also determines the quiescent DC current for the transistor, which we want to keep as low as possible. Values of 10-100k or even more are common for low power solutions. Typical values for **C2** at a quench frequency of 30KHz (useful for audio work) are between 2-5nf. The purpose of **L2** is to present a high impedance at the RF frequency and a low impedance at the quench frequency. Too large a value will cause extra ringing on the waveform at the **R1** junction. Too small a value will reduce the loop gain of the circuit. Typical values are 4-50uH.

I have made no mention of the tuning tank components or the transistor. The respective values will of course, depend on the frequency you want to operate at. I normally use a BFY90 for development, as it is good up to 800MHz, it is relatively cheap, and has decent gain characteristics at the lower frequencies. For 418/433MHz work, the coil is a one inch diameter half turn loop, and the tuning capacitor a 3-5 pf trimmer. **C3** is 1pf, and **C4** about 5pf.

You can check that the radio works by connecting **C5** to an audio amplifier and adjusting bias and component values until you hear a loud hiss. Now, you only need a modulated signal generator as a RF source. A spare keyfob alarm or car door transmitter can be a good source of 418/433MHz signals. Be careful when using these, as some models use sequential encryption

techniques which may render them out of sync with the car, if pressed too many times.

---

### **Detecting the output**

The signal at the junction of **R1** is a ramp wave of about 1-2 volts in amplitude at the quench rate **Fig 4c**. Depending on various base bias settings and component values, you will notice the dependency of quench frequency on RF signal level. Sometimes you will get a very small change in quench frequency with the signal, sometimes a much larger one. Notice how the most sensitive point needs very critical adjustments. A simple low pass filter could be used to recover the modulation. Alternatively, we could put the signal through a digital amplitude threshold and process the pulse widths as numerical values.

**Fig 3b** and **3c** show two seemingly similar variations on a simple one transistor "detector amplifier" theme. The interesting part is that one circuit works and the other does not.

To understand why, go back to **Fig 4a**, at time **t1**. With the circuit in **Fig 3b**, the quickly rising wave at the emitter has to charge not only **C2**, but also **C5**. This is because the NPN transistor **Q2** is conducting all this time. This is undesirable, as **C5** would be generally too large (in the order of microfarads). Similarly, as **R1/C2** discharges, the extra combined effect of **C5** and the base 1M resistor may drive **Q2** into non conduction prematurely. Result, a pretty inefficient detector.



Consider now **Fig 3c**. As the voltage in **R1/C2** rises quickly, **Q3** will be driven out of conduction, and **C5** is not included in the charging cycle. More importantly, as **R1/C2** starts to discharge, **C5** will slowly be brought into conduction as **Q3** starts to conduct. This has interesting effects. The overall rate of decay of the emitter waveform slows down, and **Q1** comes into conduction more slowly, resulting in a smoother introduction of negative resistance. (Remember when I mentioned the advantages of low slope negative conductance). Result, the circuit in **Fig 3c** actually increases the sensitivity of the detector.

Many other tricks have been used to improve detector performance. The general aim is to control the loop gain in order to keep it as small as possible at the onset of oscillations. **C6** in **Fig 3a** is such an example. This is used to apply a small compensating "pull" or bootstrap to the base voltage during the fast rise at **t1-t2** in **Fig 4a**. Other variations are possible.

---

### Other Circuits

**Fig 3** is just one of many possible circuits. Most well known, standard oscillator configurations can be adapted to provide self quenching. **Fig 5** shows a simple circuit with two transistors back to back. Feedback is provided by connecting the collectors directly to each other's bases, ensuring a low amplitude limited signal. This results in low power consumption and low radiation.

Fig5 (fig5.ai)

Another simple receiver. Here two transistors are used back to back in an inverting LC oscillator. Direct connection to the base emitter junctions results in low amplitude oscillations, and low power consumption. The whole radio requires less than 30 microwatts of power.

If you want to develop your own circuit, start with a standard oscillator configuration. You can find many examples in the literature at the end of this article. Choose a circuit where you can understand the purpose of each of the components. This is not so easy with many of the circuits. Next, you must identify how the components control loop gain. You can do this by arranging the oscillator to be switched on and off from a square wave source (think of this as external quenching), and watch the rise and decay of the self-oscillations on an oscilloscope as you adjust components or bias values. The slower the rate of rise, the lower the loop gain, and the better the resulting receiver. Do not worry about self quenching until you have a reliable and efficient externally quenched design. Feel free to use CAD programs to emulate the operation, but be aware that the step time of the emulation must be at the RF frequency. Some CAD programs cannot handle slow events (quenching) riding on top of fast ones (RF oscillations).

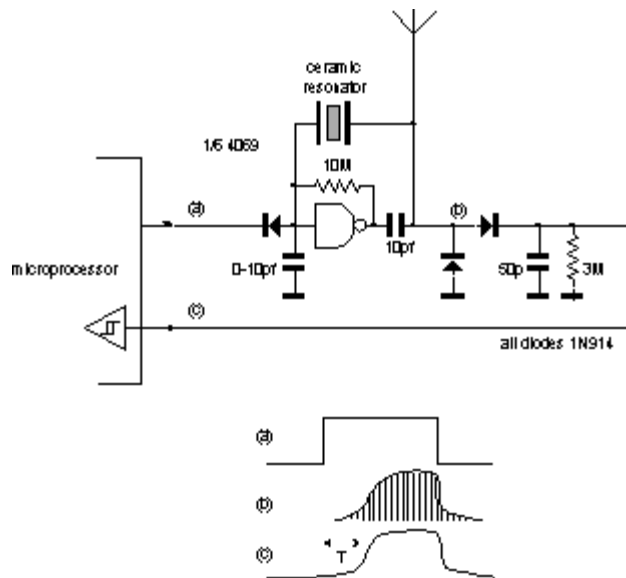

**Fig6**  
Unconventional MSF receiver. A CMOS inverter can be used, together with a 60KHz ceramic resonator in an unorthodox, but rather simple time code receiver. Here a micro controller is used to control the quenching action by gating a CMOS inverter to enter the linear state. The gate will start oscillating after a time depending on input RF excitation at the aerial. Oscillations are rectified and fed back to the micro as pulse widths for detection. The circuit can work up to 30MHz with suitable components. A crystal could also be used in this design, but with a rather limited quench rate. See text.

**Fig 6** shows an interesting variation. A CMOS 4069 inverter is used as a gated oscillator with a ceramic resonator. This can be used in a simple radio control receiver or MSF time code receiver. The external quenching action is provided by a microprocessor (the same one that may be used for processing the signal). The microprocessor starts the oscillator, and by sensing its Schmitt trigger input, measures the time period at which the oscillations have reached a threshold of about 1.5 volts. The micro then resets the oscillator, and after a suitable delay period, starts again. This circuit could also be used with a crystal but the quench frequency will be too low for other than very low speed data recovery.

Fig 7

A SAW delay line can be used to effect in the circuit shown. The various reactive components ensure a 180 degree phase shift between input and output. No part values are given, as these depend on actual unit used and layout.

**Fig 7** Shows a typical receiver circuit using a SAW delay line. I have not shown any component values, as these will strongly depend on layout and parts used. A SAW delay line has a much lower Q than a SAW resonator. I have found it quite difficult (although it is possible) to modify a standard keyfob type SAW transmitter to act as a super regenerative receiver. The loop gain of these devices is fairly high, and access to the SMD components is rather tricky.

---

### **Other interesting applications**

In theory, any active component that has negative resistance can oscillate. Therefore, there is no reason why such active component should not work in the super-regenerative mode.

Gunn diodes exhibit negative resistance characteristics, and can be used as the basis for receivers in the Gigahertz range. The easiest way to get started is by commandeering an old domestic radar intrusion detector. A popular model is the Mullard CL8960, although most modern types are very similar **Fig 8a**. This unit consists of a microwave cavity with two side by side internal sections; one with the Gunn diode, and the other with a mixer diode used for detecting the combined Doppler signal. The cavities are designed to resonate at about 10.69GHz. By operating the Gunn diode in the negative resistance region, continuous wave oscillations are generated **Fig8b**.

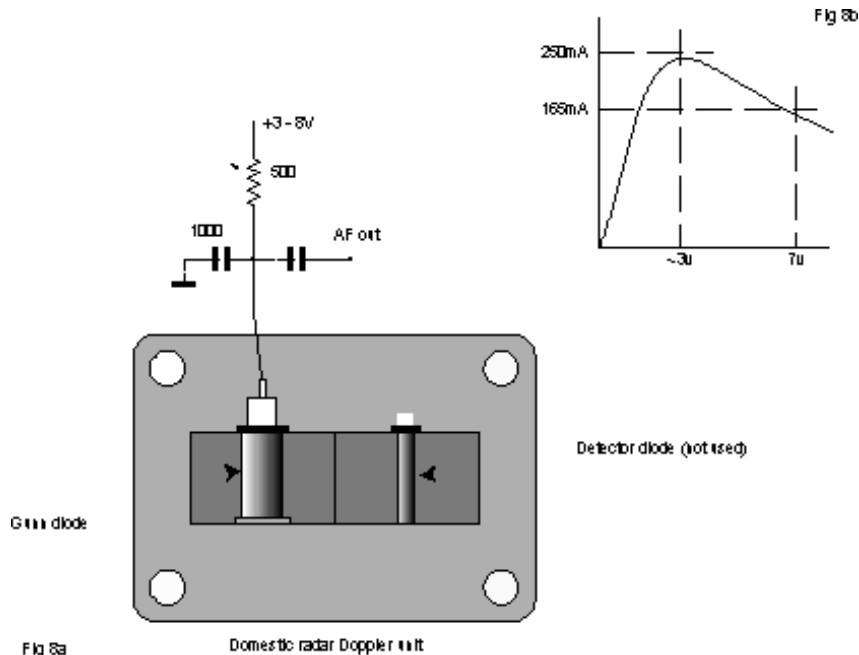

**Fig 8**

Another interesting application showing the use of a domestic radar Doppler module as a very sensitive 10GHz receiver. Using another module as the transmitter, range can be several tens of meters. The mixer diode is not used in this instance.

Self quenching can be obtained by starving the supply with a series resistor and storage capacitor to ground. Simply connect the device as shown in the figure. You may need to experiment with the values as different modules may have different characteristics. You should hear a loud "hiss" out of the amplifier and loudspeaker. You will need another Gunn unit as the transmitter. The range can be quite impressive, especially if you attach aerial horns to the flanges. You can arrange for external quenching if the unit refuses to self-quench, just switch the supply on and off at the desired quench rate. You may need a hefty switching transistor as the Gunn device can take up to 200mA.

One thing you cannot use this circuit for is as a Doppler radar module. The receiver only samples incoming radiation at the quench rate. It also radiates pulses at the same rate, but just after the detector was active, so the two signals do not meet.

Having said that, here is a simple experiment you can perform (I have not tried this). You will only need one Gunn device for this test. Arrange for the quench rate to be around 10MHz or more (you may need to use a very small value for the quench capacitor C). Alternatively, use external quenching, and arrange to measure the current into the Gunn diode, say by measuring the voltage drop across a series resistor in the supply line. Feed the two signals into an oscilloscope. The delay between the application of power and the current blip will indicate the oscillation trigger point. Point the unit at

a wall or solid object about 15 meters away. This distance should be such that a quench RF pulse will have enough time to travel to the wall and back to coincide with the exact time when the next RF quench pulse starts. The echoed signal will then react with the detector at the exact points when the next oscillations start, and produce some kind of output on the scope. What we have here is a quite accurate distance measuring device. Again, I have not tried this, but it would be interesting to see how sensitive it can be.

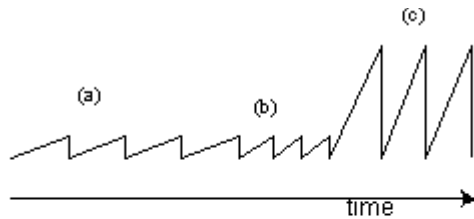

Fig9b

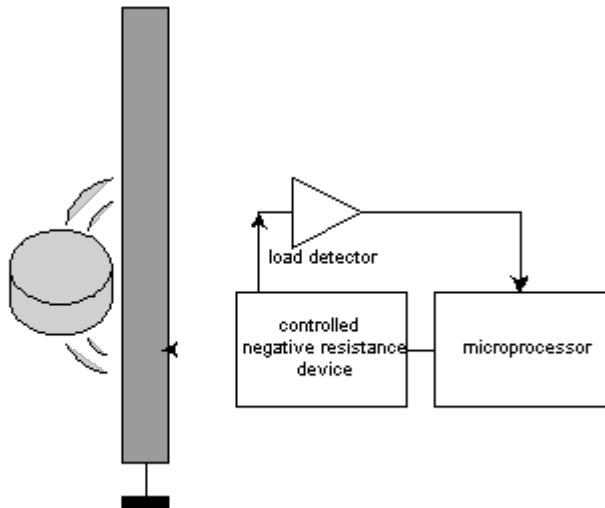

Fig9a

**Fig 9**  
A concept for a micro miniature code device or transponder. A Dielectric resonator bead is coupled to a resonant cavity or micro strip line to stabilise its operating frequency. Controlled negative resistance bursts are applied at low level (a), when acting as a sampled time receiver, and at high level (c) when acting as a transponding reply radiator.

Lastly, **Fig 9a** shows a concept for a long range miniature key fob transponder device. A resonant 1/4 wave strip line is used as both receiving and transmitting aerial. An active device source is used to sense incoming radiation by applying short duration, controlled negative conductance loads to the strip. This active source will have to be a very accurate, programmable device, e.g. a combined gyrator-controller in a chip. The sense rate can be very slow to conserve power, say once every second. When radiation is detected (from a transponder enquiry source), sense ramps are applied more often to increase the sampling rate, and to decode

any incoming addressing codes. When the unit is ready to reply, a much larger negative load is placed on the strip to provide power for radiation. The diagram shows a dielectric resonator placed close to the micro strip. Such resonators are effectively stable, high Q RF cavities constructed from solid dielectric material, and can be used to stabilise the frequency characteristics of the strip. Such a unit may work at a range of 30-50 meters.

---

### **Conclusion**

The super-regenerative concept is certainly not dead. The principle is sound, although a bad image has been caused by the use of simple designs and unstable components. By using more accurately defined components, and stable resonators, new circuits and applications are possible.

### **The Author**

Dr Eddy Insam is a consultant in innovative applications of telecommunications and specialises in graphics and signal processing. He can be reached on [edinsam@eix.co.uk](mailto:edinsam@eix.co.uk).

### **Further Reading**

Most of the original work on super regenerative receivers was done in the early 40's and during WW2. To my knowledge, there has been amazingly little published in terms of in depth coverage since then. The most interesting articles are:

Frink, F. "The Basic Principles of Super-Regenerative Reception".

*Proceedings of the IRE*, **Vol 26**, Nr1, January 1938.

Bradley W.E. "Super-regenerative Detection Theory". *Electronics*, **Vol 21**, September 1948.

Strafford F.R.W., "The super-regenerative detector: an analytical and experimental investigation". *Proceedings of the IRE* Sept 1948.

MacFarlane G.G, and Whitehead J.R., "The theory of the super-regenerative receiver in the linear mode" *Journal IEE*, **Vol 95**, part III, pp143-157, May 1946.

Some recent articles and relevant literature on oscillators and associated components:

Ian Hickman, "Practical RF Handbook" 2nd Edition, 1997. Newnes Publications. ISBN 0 7506 34472

Ian Hickman, "Superregen or superreplacement". *Electronics World* February 1999. A recent article on receiver design that mentions super-regenerative receivers.

Staff feature "Low Noise Microwave Oscillators" *Electronics World* November 1990. A short note on the design of low noise oscillators.

Martin Eccles "Applying Crystals" *Electronics World* August 1994. Useful information on the workings of crystals and associated oscillator circuits.

CAPTIONS FOR THE ARTICLE

[note to ed: All diagrams are also supplied as separate Adobe Illustrator vector files]