

FUNCTION SWITCH S2

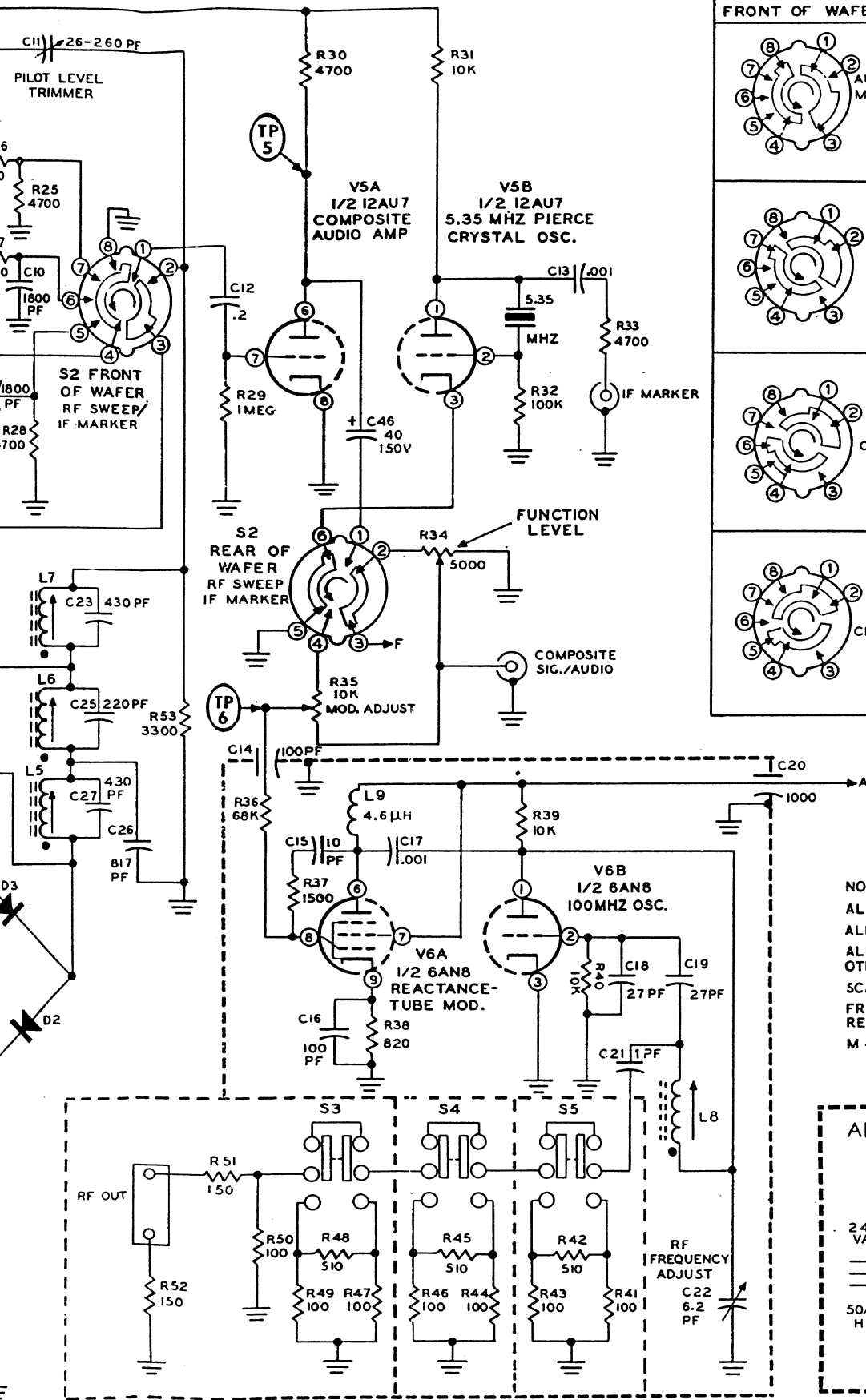

SCHMATIC OF THE HEATHKIT® FM STEREO GENERATOR MODEL IG-37

NOTE:
 ALL RESISTORS ARE 1/2 WATT UNLESS MARKED OTHERWISE.
 ALL RESISTOR VALUES ARE IN OHMS (K = 1000, M = 1,000,000).
 ALL CAPACITOR VALUES ARE IN μ FD UNLESS MARKED OTHERWISE.
 SCA SWITCH (S7) IN 67 kHz POSITION.
 FREQUENCY AND FUNCTION SWITCHES VIEWED FROM THE REAR, AT FULL COUNTERCLOCKWISE ROTATION.
 M - MUTUAL COUPLING.

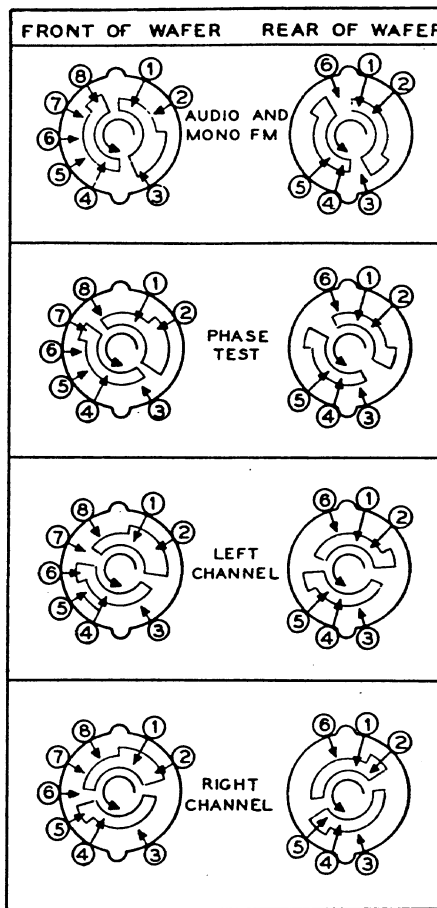