

# REVOX

Stereo-Amplifier

Model 40

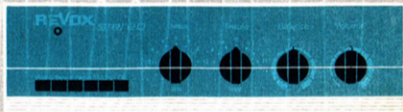

Operating Instructions

REVOX *stereo*



Phono Tape 1 Radio 2 Mono Off



REVOX

Modell 40

Made in Switzerland

Fabr. No. 100000

WILLI STUDER

Fabrik für elektron. Apparate  
Reparatur  
Zürich (Switzerland)



II Leucht- / Fernstr.



I Leucht- / Speaker



II Eingabe /  
Tape



Radio I

Radio II

Tape

Phone



100 VA

REVOX MODEL 40 AMPLIFIER

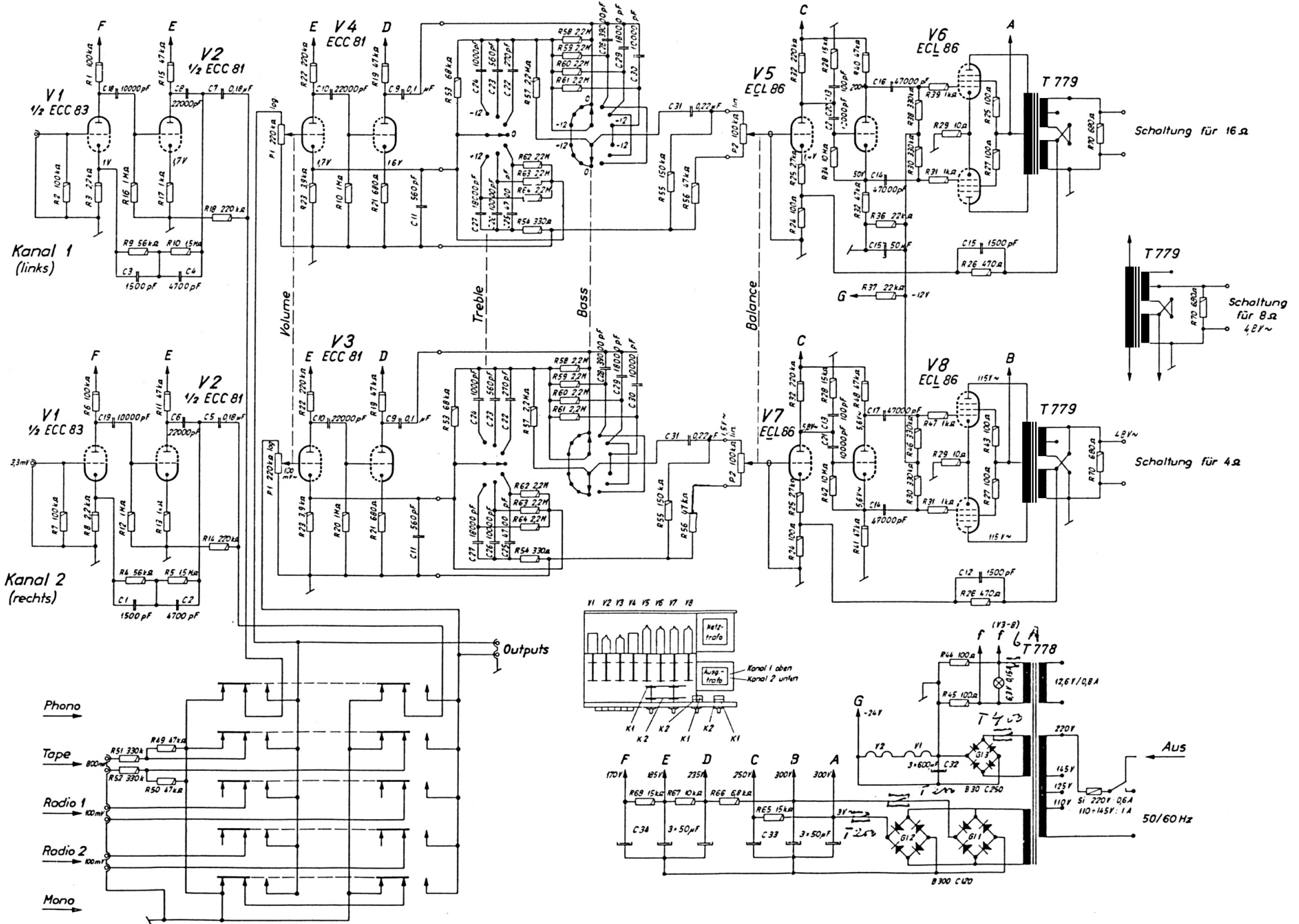

### Power output

Frequency c/s	30	40	100	1000	10,000	15,000	20,000
Watts RMS	9	14	15	15	9.4	5.5	4.4

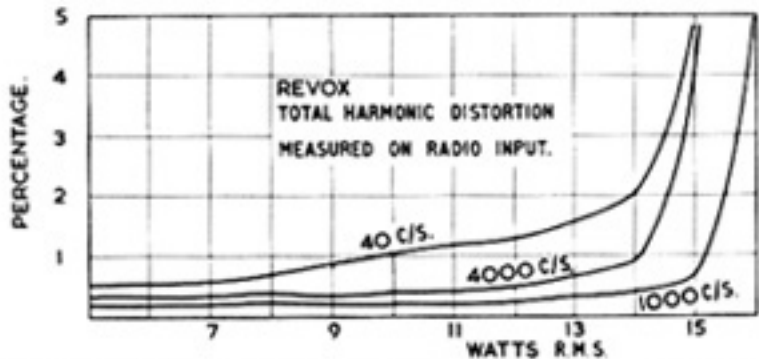

LEVEL TO 10 C/S.

REVOX  
FREQUENCY RESPONSE.

100 C/S

1,000 C/S

10 KC/S

100 KC/S

0

10

20

30

dB.

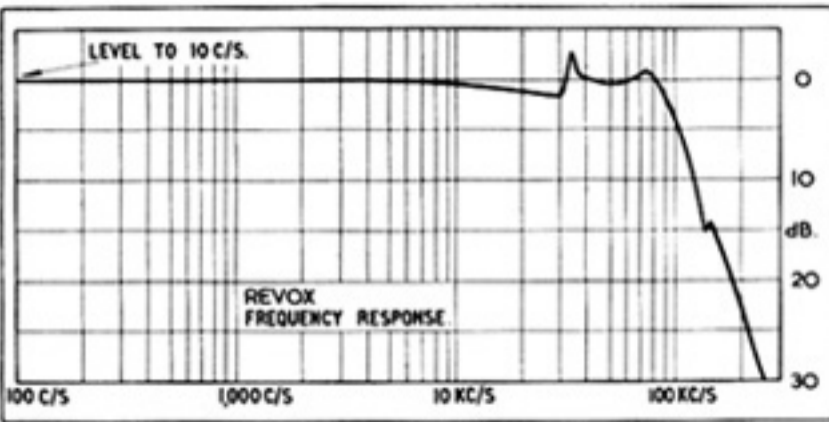

REVOX

SQUARE WAVE RESPONSE.

1KC/S.



10KC/S.



## Specifications

Inputs: PHONO (for magnetic or dynamic pickup)  
100 kOhm, asymmetrical, sensitivity 5 mV  
TAPE 300 kOhm, " " 1.2 V  
RADIO 1/2 220 kOhm, " " 150 mV

Outputs: tape, 150 mV  
speaker, 4 / 8 / 16 Ohm, switchable

Phono equalization: according to RIAA (see diagram)

"Bass" control: 7 stages of 4 db each at 50 cps; +12, +8, +4, 0, -4, -8, -12 db

"Treble" control: 7 stages of 4 db each at 10 kc; +12, +8, +4, 0, -4, -8, -12 db  
(adjustable frequency responses see diagram)

"Balance" control: adjusting range 10 db

Frequency response: 30 to 20'000 cps  $\begin{matrix} +0 \\ -1 \end{matrix}$  db, measured at radio input, bass and treble  
controls in position 0

Signal-to-noise ratio:  $\geq$  60 db for  $N_a = 10$  watts, max. volume, inputs short-circuited

Crosstalk damping:  $\geq$  60 db, 50 to 15'000 cps, max. volume, inputs short-circuited

Output power: 10 watts each channel, peak 12.5 watts

Harmonic distortion:  $\leq$  0.5 % at 10 watts and 1000 cps (see diagram)

Power supply: 110, 125, 145, 220 V a.c., 50 - 60 cps

Power consumption: about 80 watts

Tube complement: 1 x ECC 83, 3 x ECC 81, 4 x ECL 86

Overall dimensions:  $15\frac{3}{8}$  in. wide,  $10\frac{1}{2}$  in. deep,  $4\frac{1}{2}$  in. high

Weight:  $20\frac{1}{2}$  lbs.



K / IM

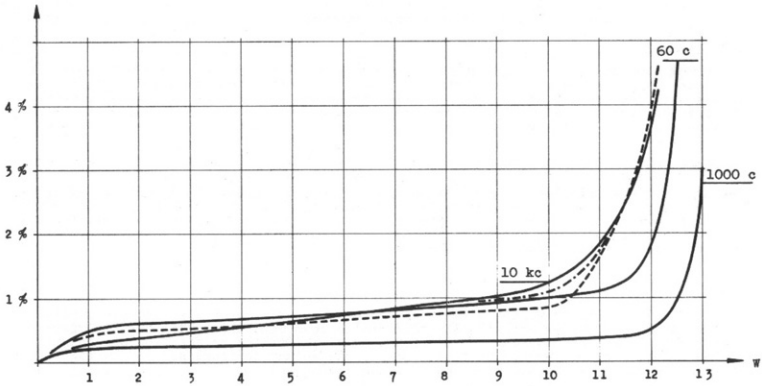

Harmonic and intermodulation distortions in function of output power, measured at RADIO input, bass and treble controls in position 0, output impedance 4 ohm.

IM distortion:  
60 / 2000 cps, 1:4 -----  
100/12000 cps, 1:4 -.-.-.-  
Harmonic distortion: \_\_\_\_\_

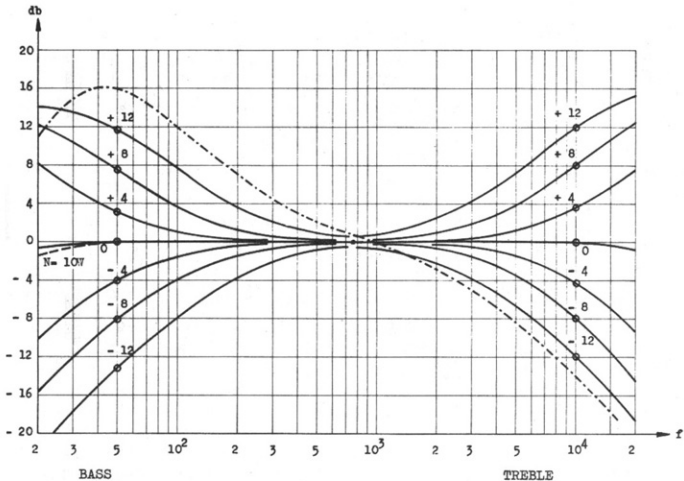

----- Frequency response input PHONO,  
bass and treble controls in  
position 0.

———— Adjustable frequency responses  
with bass and treble controls.

## Operating the Set

### Power supply

The REVOX -40- Amplifier is despatched from the works set for 220 V. Before plugging in the power supply cable secured to the set, check that the existing power supply voltage agrees with the setting of the voltage selector at the rear of the set. After removing the fuse carrier located in the center, the voltage selector can be turned with the help of a coin and set to the voltage identified by the red marking.

### Switching on - switching off

The amplifier is switched on by pressing one of the pushbuttons PHONO, TAPE or RADIO. A pilot lamp below the REVOX signet lights up when the set is alive. The pushbutton OFF serves to switch off the amplifier. The pushbutton MONO is not released by pressing the OFF pushbutton; to return it to its initial position and to make the monaural circuit ineffective, it must be fully depressed.

### BALANCE

This control permits obtaining a balanced stereo impression even when using various speaker systems or under acoustically unfavorable room conditions. Without interfering with the total volume, turning the BALANCE control shifts the volume from one channel to the other, i.e. by turning it to the right, the volume is increased in the right-hand channel and decreased to the same extent in the left-hand one.

### BASS and TREBLE

Both boosting and cutting the low and high frequencies respectively can be effected with these controls without changing reproduction of the middle frequencies. Thus it is possible, even at low volumes, to match reproduction to ear response and to tune it to the

acoustic conditions of the room and the speakers used. The controls are simultaneously effective on both channels, avoiding falsification of the acoustic pattern.

When using the phono input, it is recommended not to switch on the bass boost fully (+12 db). For compensating the cutting characteristics, a boost of 15 db is already effected in the preamplifier. Summation of the two boosts might lead to a significant increase of the interference noises caused by the phono.

## I n p u t s

Each input consists of two coaxial jacks bearing the channel notation I and II. When feeding in a two-channel information, whether from radio broadcast, stereo pickup or tape, it is important to pay attention to the conformity of the channels. Only in this way the laterally correct reproduction now standard is ensured:

Channel I     =   left-hand speaker  
Channel II    =   right-hand speaker

## P H O N O

The phono input has a sensitivity of 5 mV so that magnetic and dynamic pickup systems can be joined up without interposing a transformer. The record compensation according to the RIAA standard is effected in the preamplifier ensuring linear frequency response when playing back modern longplay records.

If a crystal pickup is used, the system must be damped by a resistance of 5 to 10 kOhm as per diagram below. This type of circuitry, which is only possible in conjunction with a highly sensitive amplifier, gives the following advantages compared with conventional high-resistance matching:

- Linearizing frequency response, small harmonic and intermodulation distortions of the pickup cartridge, low-resistance conductor phono-amplifier thus low hum voltages, i.e. greater signal-to-noise voltage ratio. -

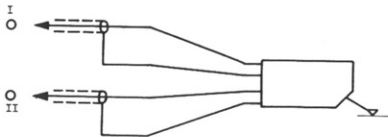

Connection of a magnetic or dynamic stereo pickup.

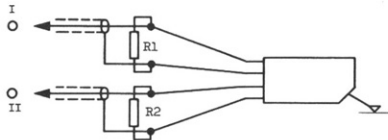

Connection of a crystal stereo pickup, values of R1 and R2 : 5 to 10 kOhm, depending on the voltage supply.

## T A P E

As regards its sensitivity this input is matched to the REVOX D 36 tape recorder. Connect the cathode follower outputs I and II of the tape recorder with the respective TAPE jacks of the amplifier.

## R A D I O 1/2

These two double inputs are intended for connection to a radio or television set, an ultra-short-wave tuner, a wire broadcast set or a tape recorder with preamplifier.

## O u t l e t s

### OUTPUTS

If a signal is not only to be amplified for speaker reproduction but also to be fed to a tape recorder for preservation on a tape unaffected by the controls VOLUME, BALANCE, BASS and TREBLE, connection of the tape recorder is made to the jacks OUTPUTS I and II. If connection is made to a REVOX D 36 tape recorder, the input "Diode" on the recorder must be used. Depending on the pushbutton position the inputs TAPE and RADIO 1/2 of the -40- Amplifier are led back to these outputs with the same level. In position PHONO, the signal amplified and compensated according to the RIAA curve reaches these output jacks with a level of 150 mV. The input resistance of the tape recorder must be at least 200 kOhm.

### SPEAKERS

Connection of the two speakers is through the double jacks suitable for banana-type plugs marked LAUTSPRECHER/SPEAKER I and II. The speaker located at the left, when viewed

from the front, is connected to channel I, that on the right to channel II. Make sure the speaker connections have the correct polarity so that emission will be in phase.

These outlets of the two 10 watt output stages can be switched for speaker impedances of 4, 8 and 16 ohm. When supplied, the apparatus is set for 4 ohm. Change-over is effected by resoldering the connections of the output transformers according to the diagram shown below.

Caution! If only one speaker is connected up, the output not being used must be loaded with a resistance of 10 ohm.

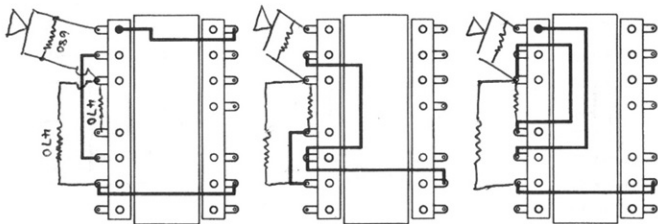

16  $\Omega$

8  $\Omega$

4  $\Omega$

Setup of a stereo system

Channel I

Channel II

