

REVISION RECORD			
LTR	ECO NO:	APPROVED:	DATE:

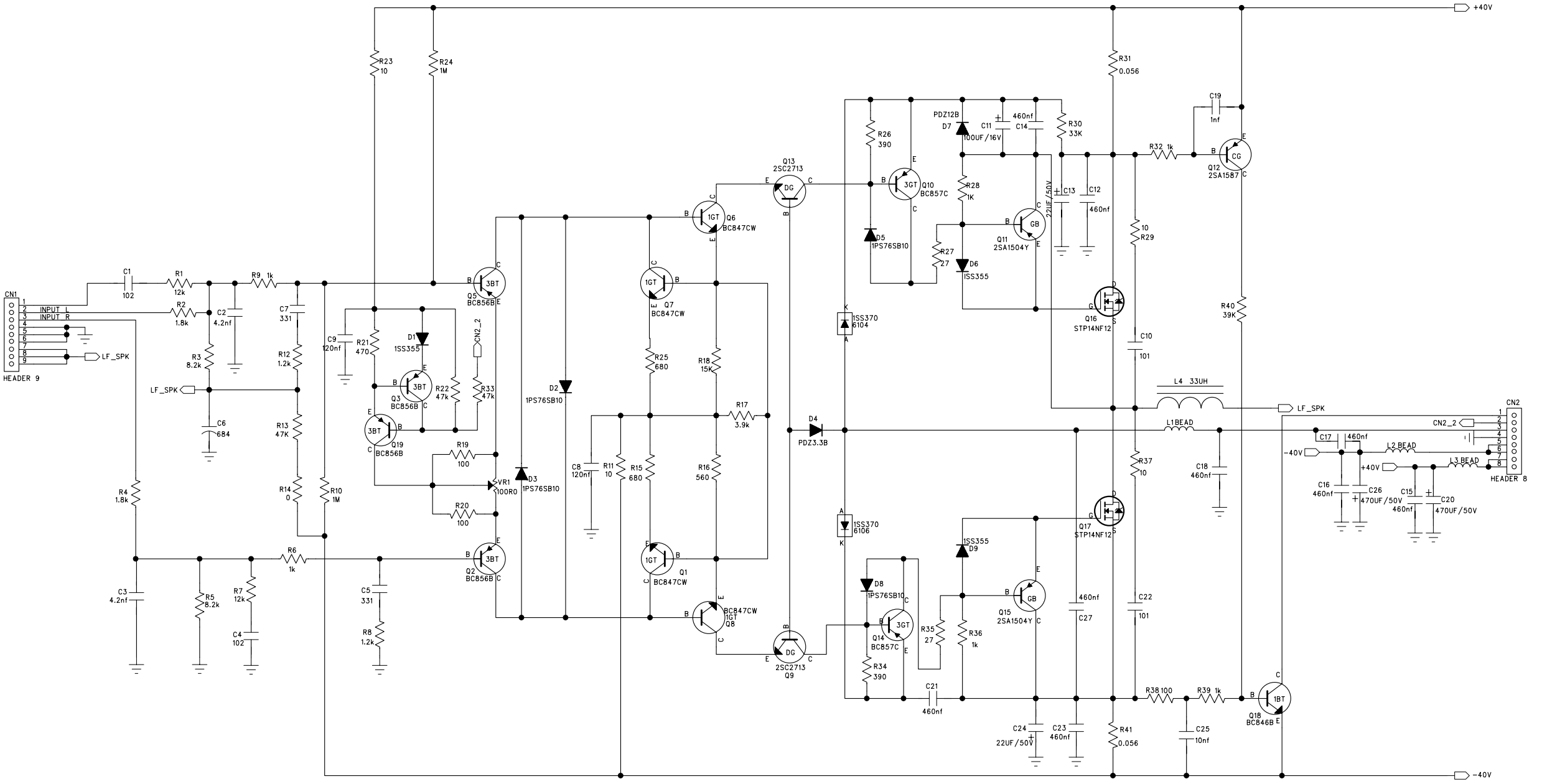

COMPANY: HAILIN

TITLE: PSK-50 MAIN AMP

DRAWN: 2007.3.30	DATED:
CHECKED:	DATED:
QUALITY CONTROL:	DATED:
RELEASED:	DATED:

CODE:	SIZE:	DRAWING NO:	REV: 2.0
XUDAFANG			SHEET: OF

REVISION RECORD			
LTR	ECO NO:	APPROVED:	DATE:

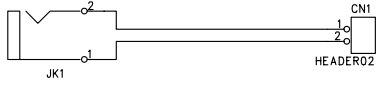

COMPANY: HAILIN			
TITLE: PSK-50 OUTPUT			
CODE:	SIZE:	DRAWING NO:	REV: 2.0
SCALE:		SHEET: OF	

DRAWN: 2006.12.6	DATED:
CHECKED:	DATED:
QUALITY CONTROL:	DATED:
RELEASED:	DATED:

REVISION RECORD			
LTR	ECO NO:	APPROVED:	DATE:

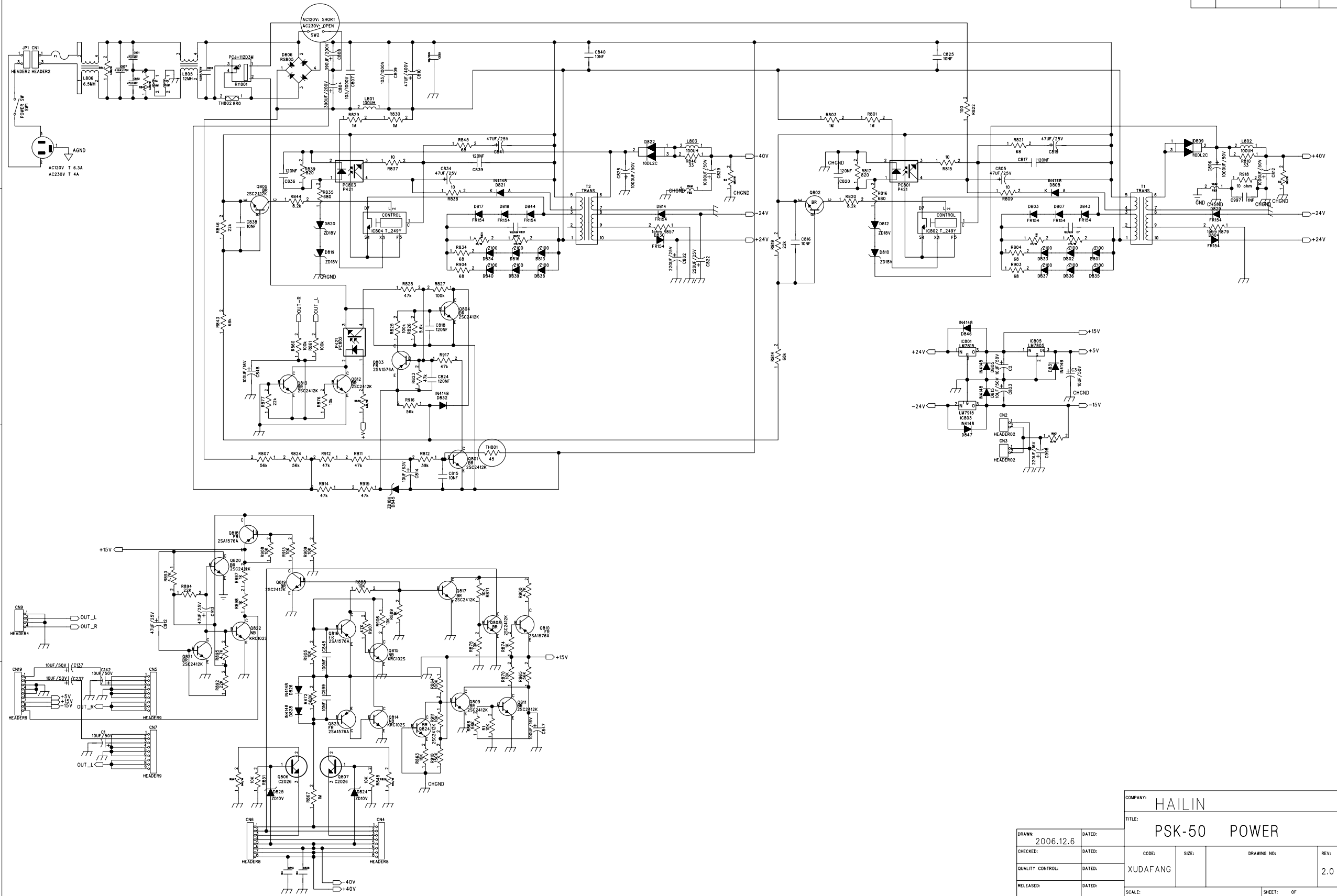

COMPANY: HAILIN	
TITLE: PSK-50 POWER	
DRAWN: 2006.12.6	DATED:
CHECKED:	DATED:
QUALITY CONTROL:	DATED:
RELEASED:	DATED:
CODE: XUDAFANG	SIZE:
DRAWING NO:	REV: 2.0
SCALE:	SHEET: OF

REVISION RECORD			
LTR	ECO NO:	APPROVED:	DATE:

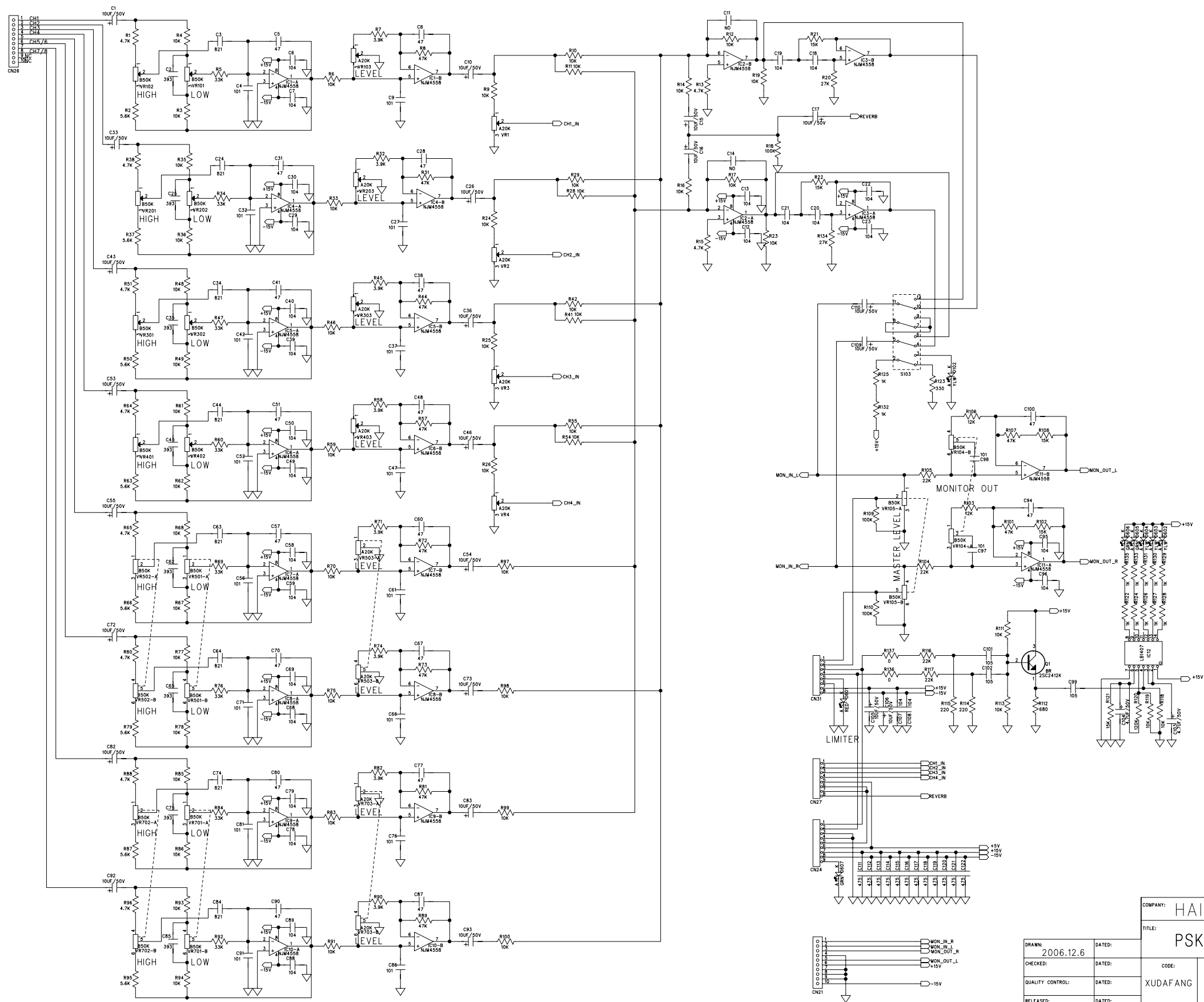

COMPANY: HAILIN		TITLE: PSK-50 PRE AMP	
DRAWN: 2006.12.6	DATED:	CODE:	SIZE:
CHECKED:	DATED:	DRAWING NO:	REV: 2.0
QUALITY CONTROL:	DATED:	XUDAFANG	
RELEASED:	DATED:	SCALE:	SHEET: 01

REVISION RECORD			
LTR	ECO NO:	APPROVED:	DATE:

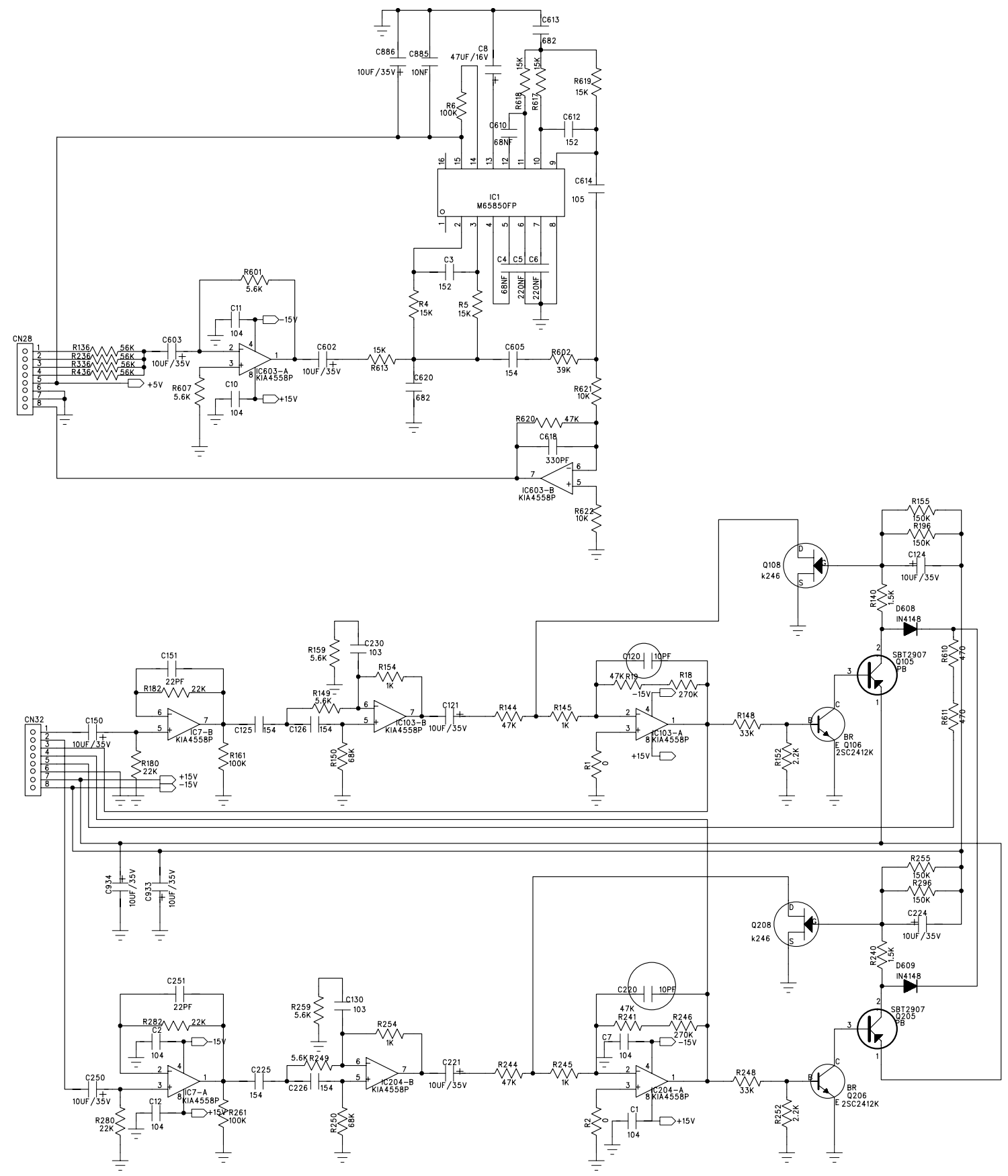

DRAWN: 2006.12.6	DATED:
CHECKED:	DATED:
QUALITY CONTROL:	DATED:
RELEASED:	DATED:

COMPANY: HAILIN			
TITLE: PSK-50 REVERB			
CODE:	SIZE:	DRAWING NO:	REV: 2.0
SCALE:			SHEET: OF

REVISION RECORD

LTR	ECO NO:	APPROVED:	DATE:

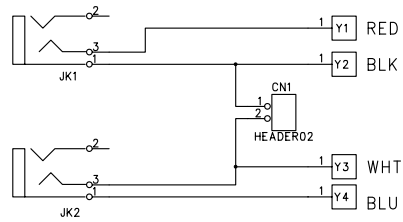

COMPANY:				HAILIN	
TITLE:				PSK-50 SP OUT	
CODE:	SIZE:	DRAWING NO:		REV:	
XUDAFANG				2.0	
SCALE:			SHEET: OF		

DRAWN:	2006.12.6	DATED:	
CHECKED:		DATED:	
QUALITY CONTROL:		DATED:	
RELEASED:		DATED:	

REVISION RECORD			
LTR	ECO NO:	APPROVED:	DATE:

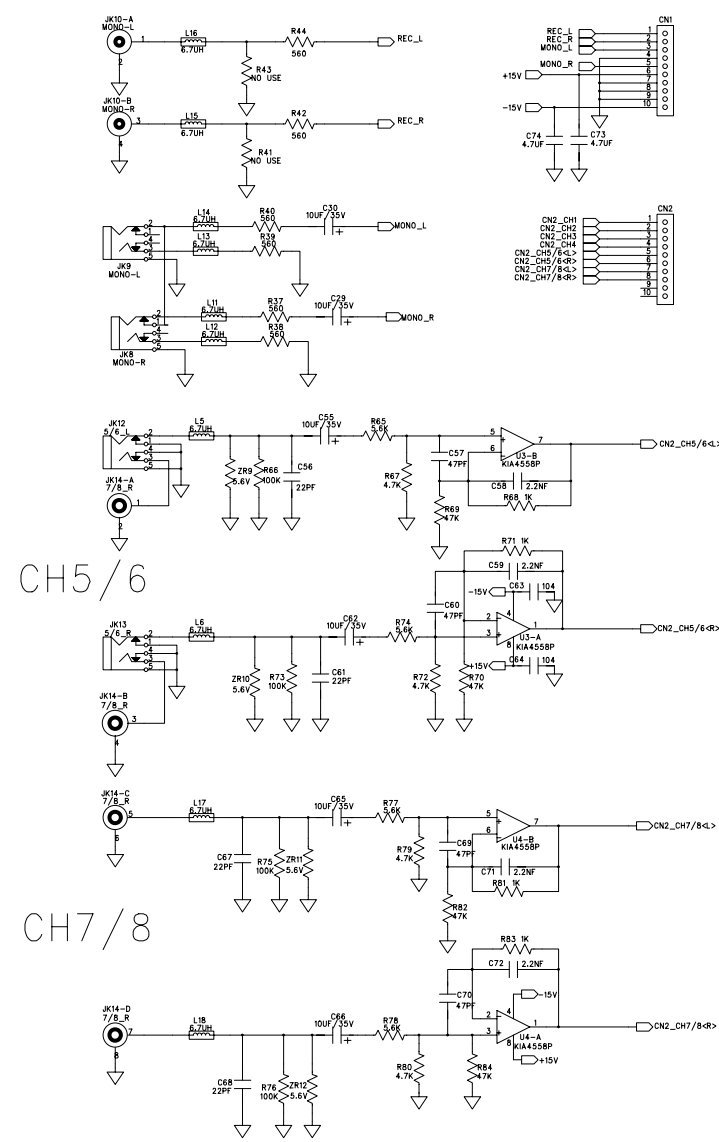
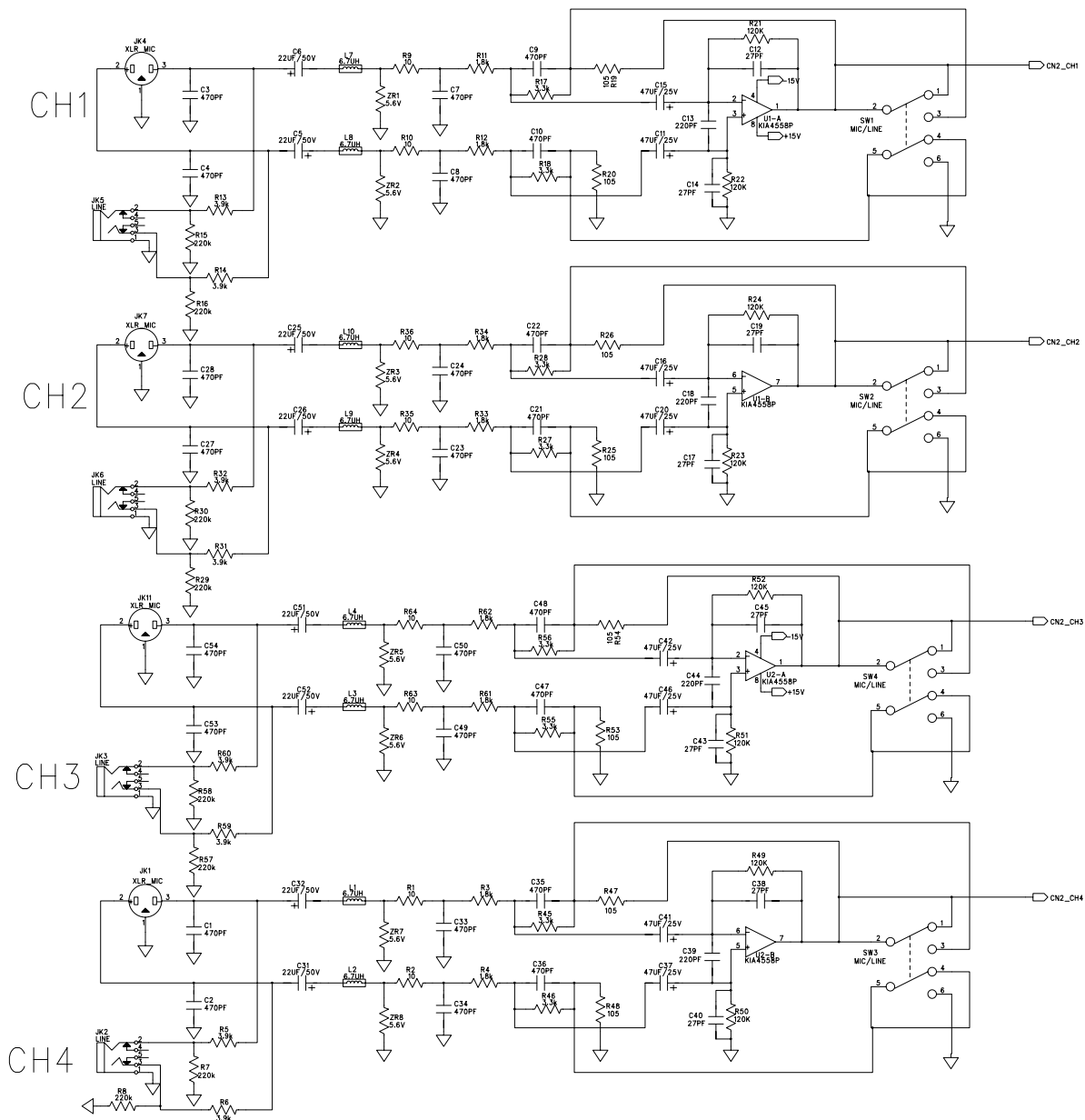

COMPANY: HAILIN		TITLE: PSK-50 INPUT	
DRAWN: 2006.12.6	DATED:	CODE:	SIZE:
CHECKED:	DATED:	DRAWING NO:	REV: 2.0
QUALITY CONTROL:	DATED:	XUDAFANG	
RELEASED:	DATED:	SCALE:	SHEET: OF

REVISION RECORD			
LTR	ECO NO:	APPROVED:	DATE:

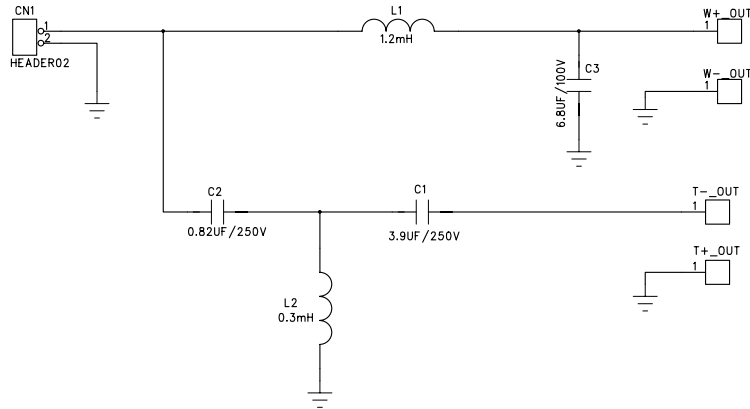

COMPANY: HAILIN			
TITLE: PSK-50 NETWORK			
CODE:	SIZE:	DRAWING NO:	REV: 2.0
SCALE:			SHEET: OF

DRAWN: 2006.12.6	DATED:
CHECKED:	DATED:
QUALITY CONTROL:	DATED:
RELEASED:	DATED: