



SERVICE MANUAL **1090**

Classic-Audio-Service
HiFi-Service-Center
Heinz Deppermann, Dipl.-Ing.
service@cas-germany.com
Tel. +49 (0) 2065 - 959085



marantz

model 1090

Stereo Console Amplifier

TABLE OF CONTENTS

SECTION	PAGE
1. INTRODUCTION	1
2. PRE-AMPLIFIER	1
3. MAIN AMPLIFIER	1
4. TROUBLESHOOTING ANALYSIS	1
5. POWER AMPLIFIER ADJUSTMENT	1
6. TEST EQUIPMENT REQUIRED FOR SERVICING	2
7. PERFORMANCE VERIFICATION	2
8. VOLTAGE CONVERSION	5
8.1 Voltage Conversion Chart	5
9. MAJOR COMPONENT LOCATIONS	6
9.1 Front Panel Adjustment and Component Locations	6
9.2 Main Chassis Component Locations (Top View)	7
9.3 Rear Panel Adjustment and Component Locations	7
9.4 Main Chassis Component Locations (Bottom View)	7
10. DIAGRAM AND COMPONENT LOCATIONS	8
10.1 Tone Component Assembly (PF01) Schematic Diagram and Component Locations	8
10.2 Rear Panel Assembly (PV00) Schematic Diagram and Component Locations	9
10.3 Speaker Switch Assembly (PS01) Schematic Diagram and Component Locations	10
10.4 Pre-Amp. Assembly (P400) Schematic Diagram and Component Locations	11
10.5 Main Amp. Assembly (P700) Schematic Diagram and Component Locations	13
11. CONNECTION DIAGRAM	15
12. SCHEMATIC DIAGRAM	17
13. EXPLODED MECHANICAL DIAGRAM	19
14. PACKING MATERIAL EXPLODED VIEW	22
15. BLOCK DIAGRAM	23
16. PARTS LIST	24
17. TECHNICAL SPECIFICATIONS	30

1. INTRODUCTION

This service manual was prepared for use by Authorized Warranty Stations and contains service information for the Marantz Model 1090 Stereo Console Amplifier. Servicing information and voltage data included in this manual are intended for use by knowledgeable and experienced personnel only. All instructions should be read carefully. No attempt should be made to proceed without a good understanding of circuitry operation.

The parts list furnishes complete ordering information. Most replacement parts should be ordered from the Marantz Company. However, a simple description is included for parts which can be obtained locally.

2. PRE-AMPLIFIER

Signals from the input jacks (TUNER, AUX, TAPE 1 & TAPE 2) are applied to the selector switch.

Signals from the PHONO 1 and PHONO 2 jacks are applied to the other section of the selector switch, then to the phono-amplifier and equalized for proper frequen-

3. MAIN AMPLIFIER

The main amplifier consists of differential pre-amplifiers Q701 and Q703, class "A" driver Q707, Q709 and direct-coupled drivers Q717 and Q719.

Q713 and Q715 act as current limiters.

cy response. The gain of the phono-amplifier (Q401, Q403 and Q405) is 40dB.

The outputs of the phono-amplifier are fed to the selector switch. The selector switch selects one of signals from PHONO 1, PHONO 2, TUNER, AUX, TAPE 1, TAPE 2 jacks and feeds it to the TAPE MONITOR switch and TAPE OUT jacks. The selected signal is then applied to the MODE switch, to the balance and volume controls, and finally to the pre-amplifier consisting of QE01, QE03, QE05 and QE07.

The frequency response is controlled by the Bass, Middle and Treble controls and the resultant output is passed to the PRE OUT jacks through the High-cut filter networks. These networks are switched in and out of the circuit by the filter switches.

4. TROUBLESHOOTING ANALYSIS

1. Excessive line consumption
 - a. Check for shorted Q801, through Q804.
 - b. Check for shorted transistor H001, through H004.
 - c. Check for open H005, H006, R733, R734.
2. No line consumption or zero bias voltage
 - a. Check line cord, fuse, check for shorted H005, H006, R733, R734.
 - b. Check for open rectifiers Q801, Q802 or open L001.
3. High hum and noise level
 - a. Check filter capacitors C809, C810, C803, C807.
4. Parasitic oscillation
 - a. Check C707, C708, C709, C710, C727, C728.

5. POWER AMPLIFIER ADJUSTMENT

ADJUSTMENT OF IDLING CURRENT

Connect a vacuum voltmeter to between emitters Q721 and Q723. Adjust R771 until 12 mA is reached. Likewise, adjust Q724, Q722 and R722.

6. TEST EQUIPMENT REQUIRED FOR SERVICING

Table 1 lists the test equipment required for servicing the Model 1090 Stereo Console Amplifier. The wattmeter, AC voltmeter, and variable autotransformer may be assembled as a test fixture as shown schematically in Figure 1. The load resistors and AC ammeter may be assembled into a second test fixture as shown in Figure 2.

Line Switch	OFF
Variable-line switch	Variable
Wattmeter Switch	ON
Variable Autotransformer	0 V (fully CCW)
Load	8 ohms (0.5 mfd - OFF)
Audio Generator	1 kHz
Output	5 V range
Gain	Minimum
AC VTVM	30 V range

7. PERFORMANCE VERIFICATION

TEST PROCEDURE

A. TEST EQUIPMENT

Refer to Table 1 for required test equipment.

B. PRELIMINARY PROCEDURES

1. Make the test setup shown in Figure 1 with the instrument controls set in the following positions:
2. Make sure that connections between the resistive load and the system terminals of the Model 1090 have negligible resistance when compared with the resistance of the load itself. Appreciable resistance in wiring adds to the total load, resulting in inaccurate measurements of output power.
3. Connect amplifier output to load and connect AC cord to line power. Connect shorting plugs to the Phono input jacks of the Model 1090.

Table 1. Test Equipment Required for Servicing

Item	Manufacturer and Model No.	Use
Distortion Analyzer Audio Oscillator AC VTVM	Sound Technology Model 1700B	Distortion measurements Sinewave and squarewave signal source voltage measurements (AC)
Oscilloscope	Tektronix Model T932 Philips Model 3232	Waveform analysis and trouble shooting and ASO alignment
Circuit Tester		Trouble shooting
DC VTVM	Fluke Model 8000 "Digital" Simpson Model 313, Triplet Model 801	Voltage measurements (DC)
AC Wattmeter	Simpson Model 1379	Monitors primary power to amplifier
AC Ammeter	Commercial Grade (1~10 A)	Monitors amplifier output under short circuit condition
Line Voltmeter	Simpson Model 1359	Monitors potential of primary power to amplifier
Variable Autotransformer	Superior Electronic Co., Powerstat Model 116B-10A	Adjusts level of primary power to amplifier
Shorting Plug	Use phono plug with 600 ohm across center pin and shell	Shorts amplifier input to eliminate noise pickup
Output Load (8 ohms, ±0.5% 100 W)	Commercial Grade	Provides 8-ohm load for amplifier output termination
Output Load (4 ohms, ±0.5% 100 W)	Commercial Grade	Provides 4-ohm load for amplifier output termination
Output Load Capacitor (0.5 mfd)	Mylar	Provides capacitive load for instability checks
AC Power Control Box	Optional Item. Fabricate in accordance with Figure 1	Monitors and controls primary power for amplifier
Amplifier Output Load Box	Optional Item. Fabricate in accordance with Figure 2	Provides various amplifier loads and can monitor shorted output

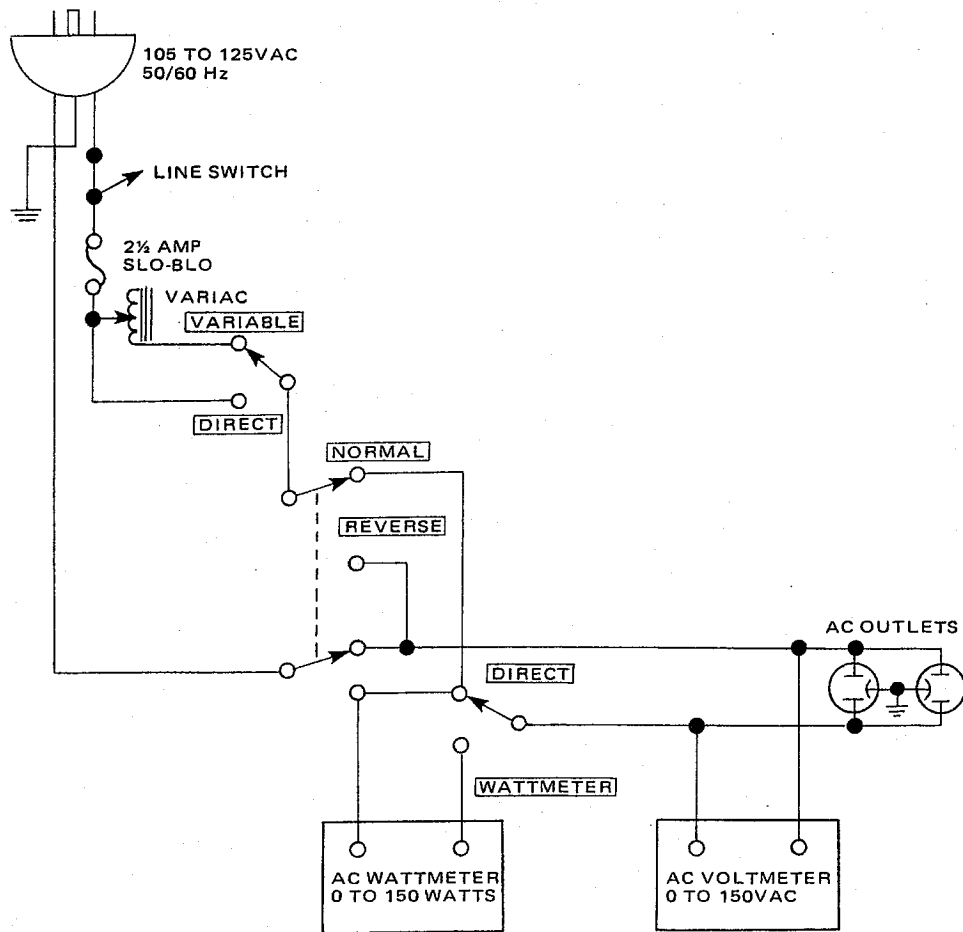

Figure 1. AC Power Control Box Simplified Schematic

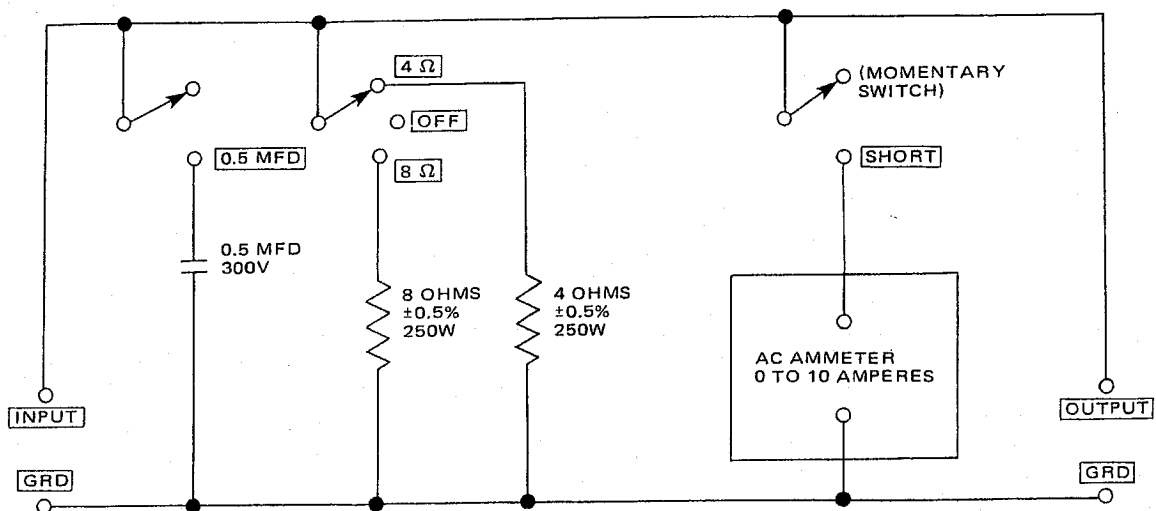

Figure 2. Amplifier Output Load Box Simplified Schematic

C. TOTAL HUM AND NOISE TEST

1. With shorting plugs connected to the Phono input jacks and an 8 ohm resistive load connected across the speaker system output terminals, connect a distortion analyzer across the load.

NOTE:

If the distortion analyzer does not contain a built-in voltmeter, an AC VTVM may be substituted.

2. Set the distortion analyzer controls for voltage measurements and apply power to the amplifier. Set the volume control fully CCW. Set the SELECTOR switch to PHONO.
3. If the distortion analyzer indicates more than 2.0 mV, refer to the trouble analysis section of this manual.
4. Set the volume control fully CW. If the distortion analyzer indicates more than 20 mV, refer to the trouble analysis section of this manual.

D. MAXIMUM POWER OUTPUT

1. Connect the audio oscillator to the AUX input. Set audio oscillator frequency to 1 kHz. Set SELECTOR switch to AUX.
2. With the distortion analyzer connected across the output load (8-ohm), set the analyzer on the 30 VAC scale.
3. Turn the analyzer on and increase the audio oscillator output to 180 mV. The AC VTVM should read 16.8 VAC or more.

E. HARMONIC DISTORTION TEST

1. Set the frequency of the audio oscillator and the distortion analyzer to 20 kHz.
2. Set the controls of the analyzer for voltage measurement on the 30 volt scale.
3. Adjust the audio oscillator output level until the analyzer meter indicates 16.8 VAC.
4. Switch the distortion analyzer to Set Level and adjust SENSITIVITY for full scale reading on 0 ~ 1% scale.
5. Measure the total harmonic distortion with the analyzer and verify it is less than 0.1%.

NOTE:

Any parasitic oscillation in the amplifier will be displayed on the oscilloscope when capacitance is switched into the load.

6. Switch the distortion analyzer back to SET LEVEL. (Do not readjust sensitivity of analyzer.)
7. Change the frequency of the audio oscillator and distortion analyzer to 1 kHz. Adjust audio oscillator output for a full scale reading on the 0 ~ 1% scale.
8. Measure the distortion, verifying it is no greater than 0.1%.
9. Repeat steps 7 and 8, changing frequency to 20 Hz. Distortion should be no more than 0.1%.
10. Check for parasitic oscillation; there should be none.

● EUROPEAN MODEL ONLY

8. VOLTAGE CONVERSION

This Model is equipped with a universal power transformer to permit operation at 110, 120, 220 and 240 V AC 50/60 Hz.

To convert the unit to the required voltage, set the plug as illustrated so that you can adjust the voltage as required.

CAUTION
DISCONNECT POWER SUPPLY CORD FROM AC OUTLET BEFORE CONVERTING VOLTAGE.

8.1 Voltage Conversion Chart

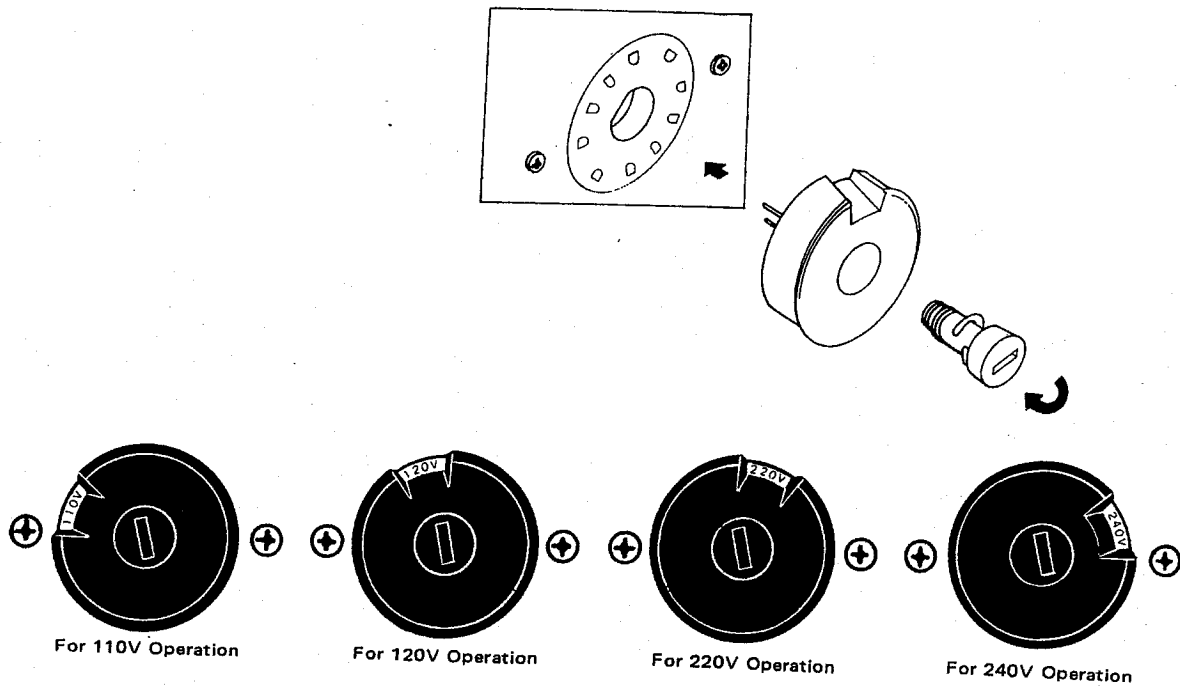

9. MAJOR COMPONENT LOCATIONS

9.1 Front Panel Adjustment and Component Locations

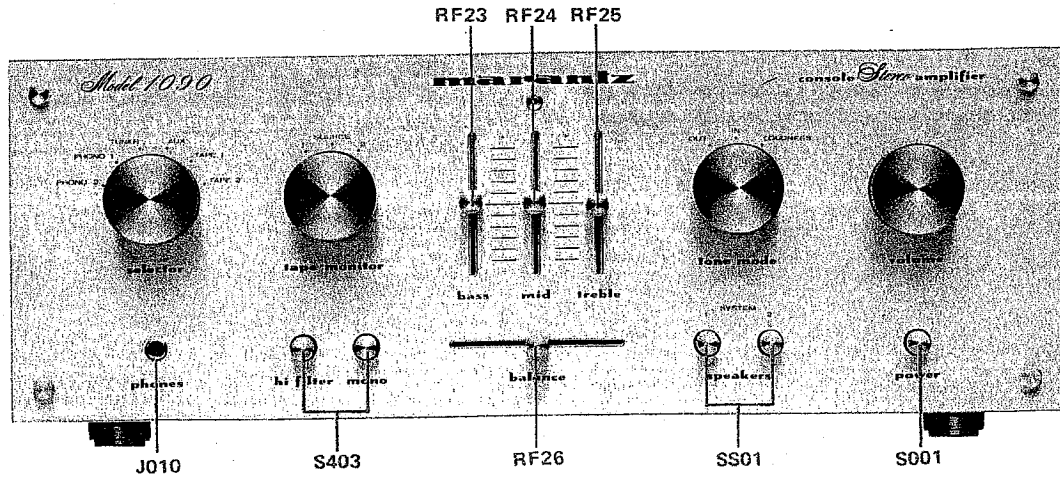

9.2 Main Chassis Component Locations (Top View)

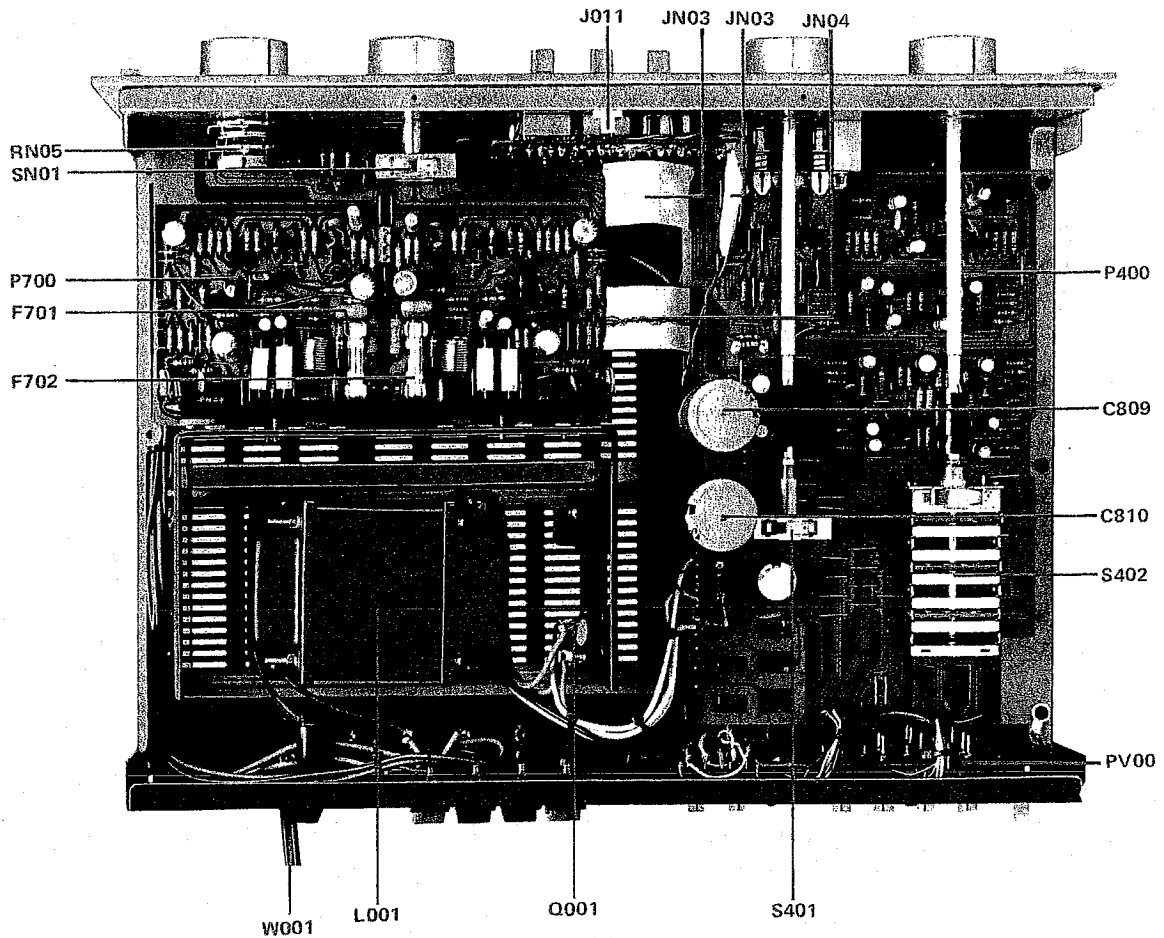

9.3 Rear Panel Adjustment and Component Locations

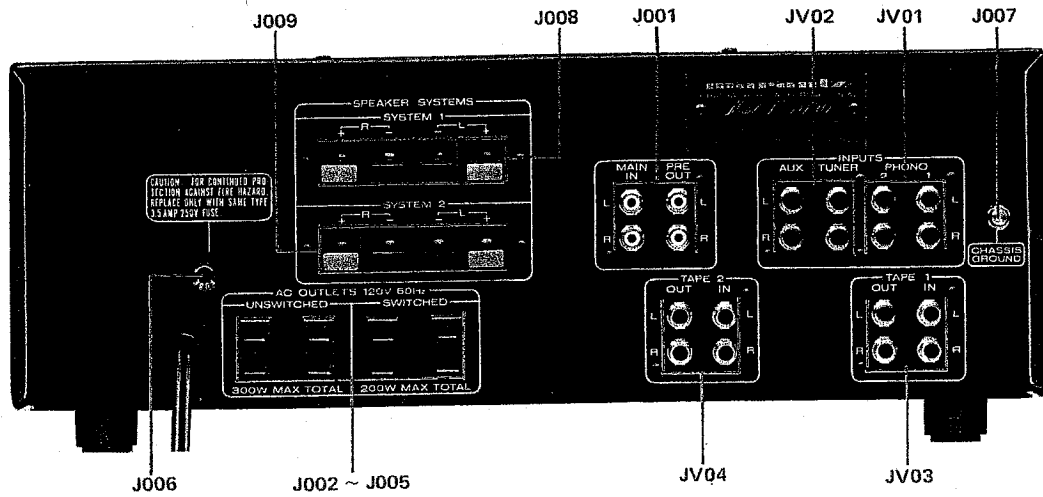

9.4 Main Chassis Component Locations (Bottom View)

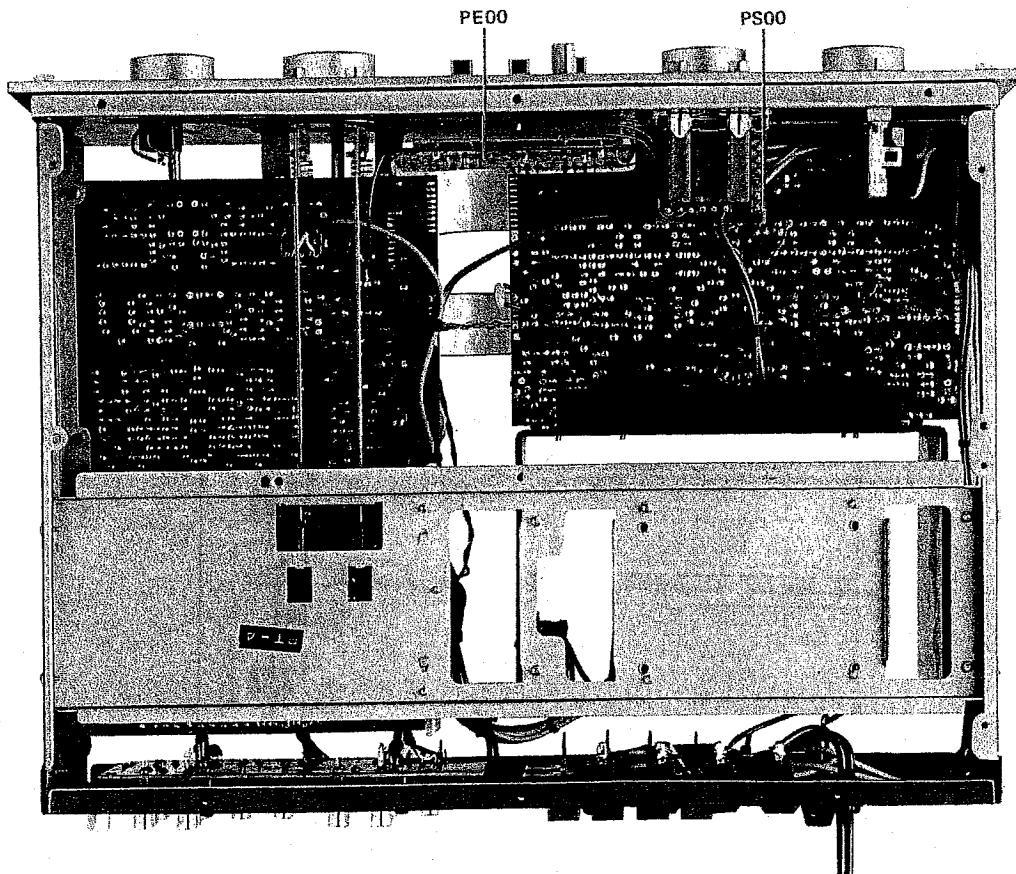

10. DIAGRAM AND COMPONENT LOCATIONS

10.1 Tone Component Assembly (PF01) Schematic Diagram and Component Locations

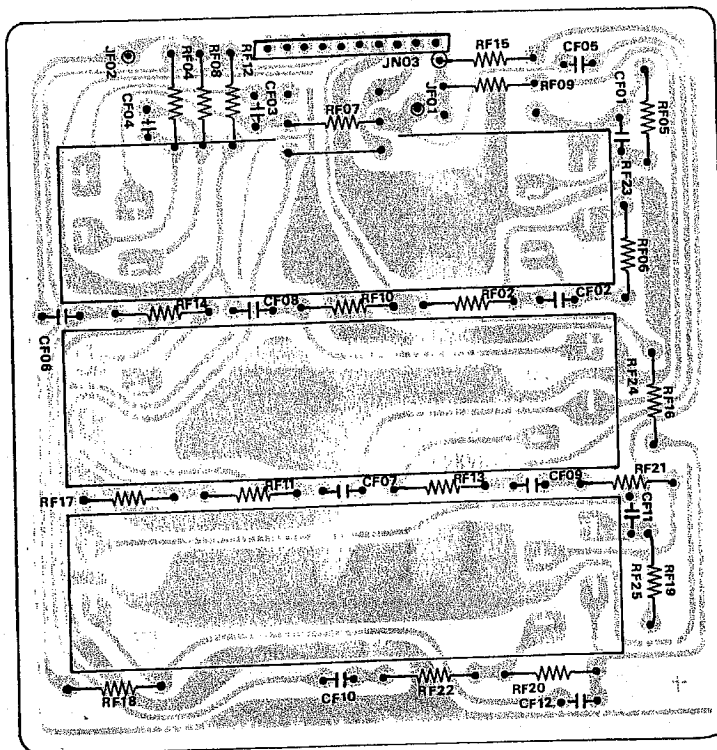
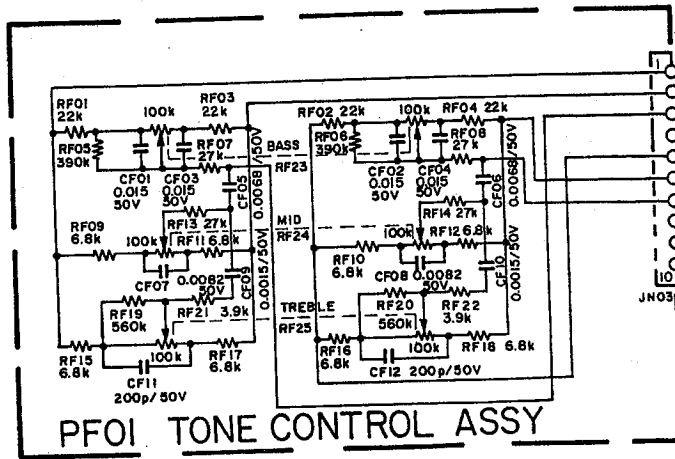

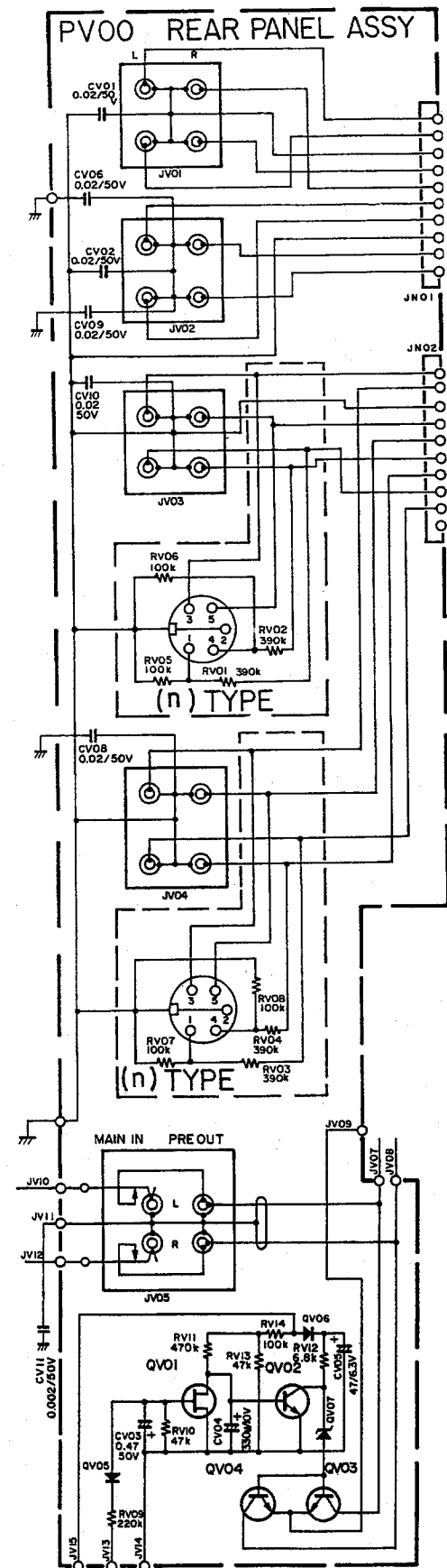

10.2 Rear Panel Assembly (PV00) Schematic Diagram and Component Locations

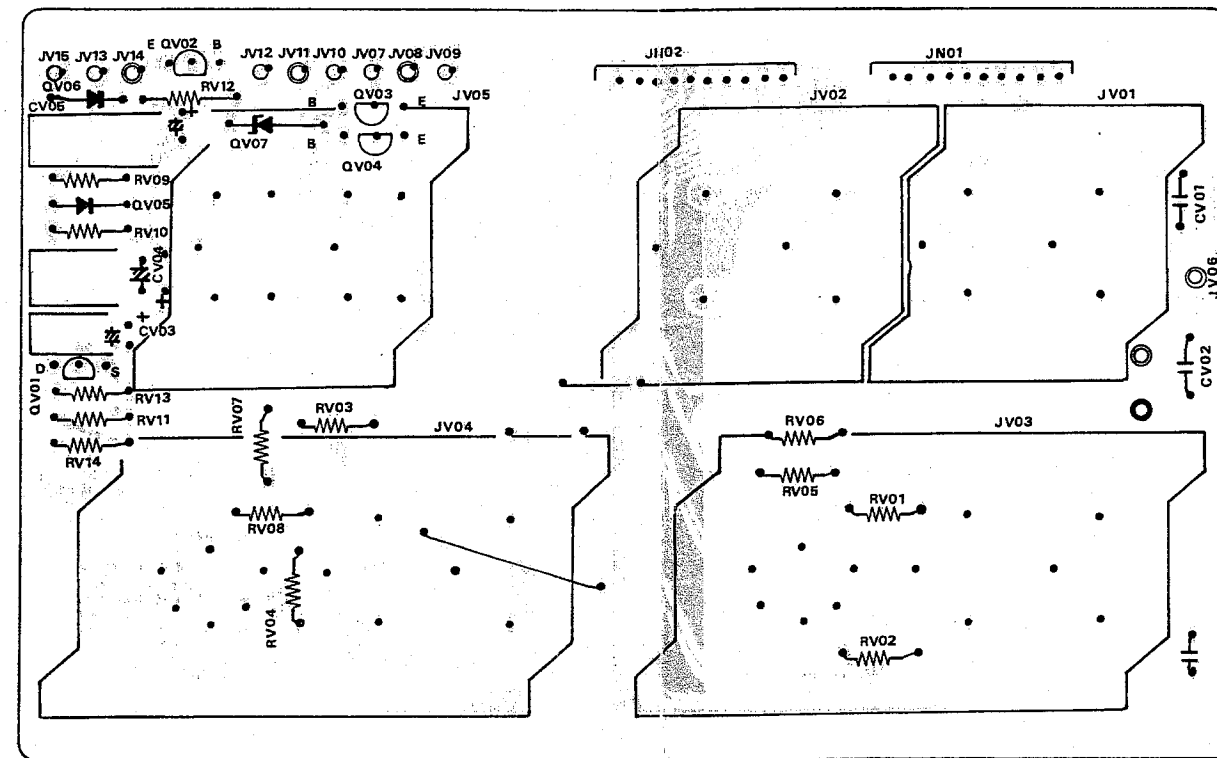

10.3 Speaker Switch Assembly (PS00) Schematic Diagram and Component Locations

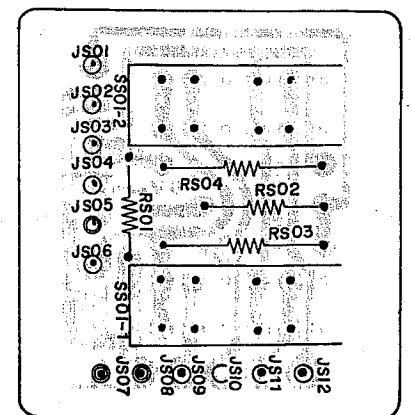
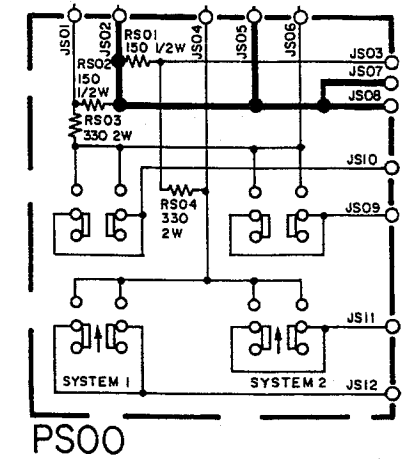

10.4 Pre-Amp. Assembly (P400) Schematic Diagram and Component Locations

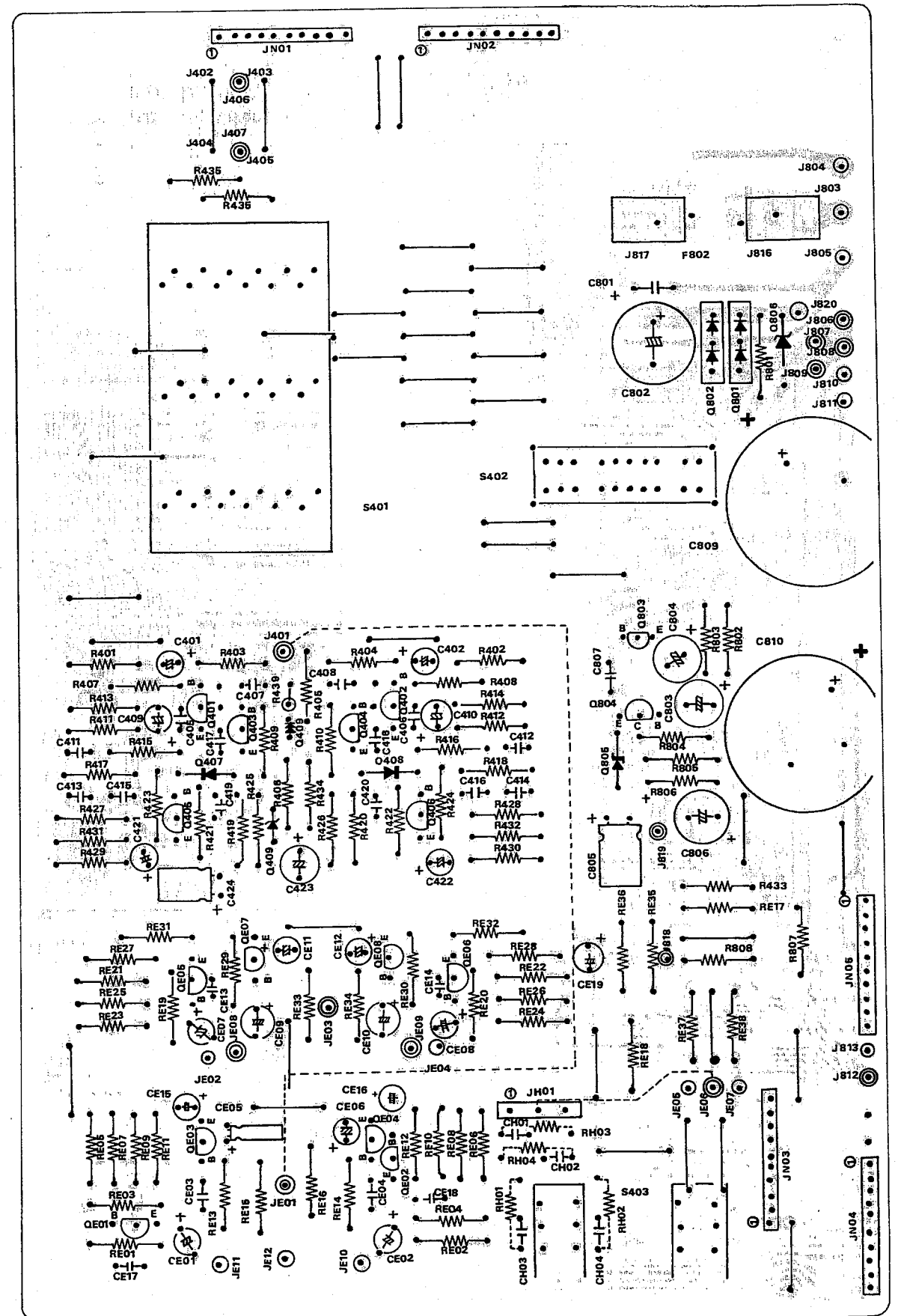
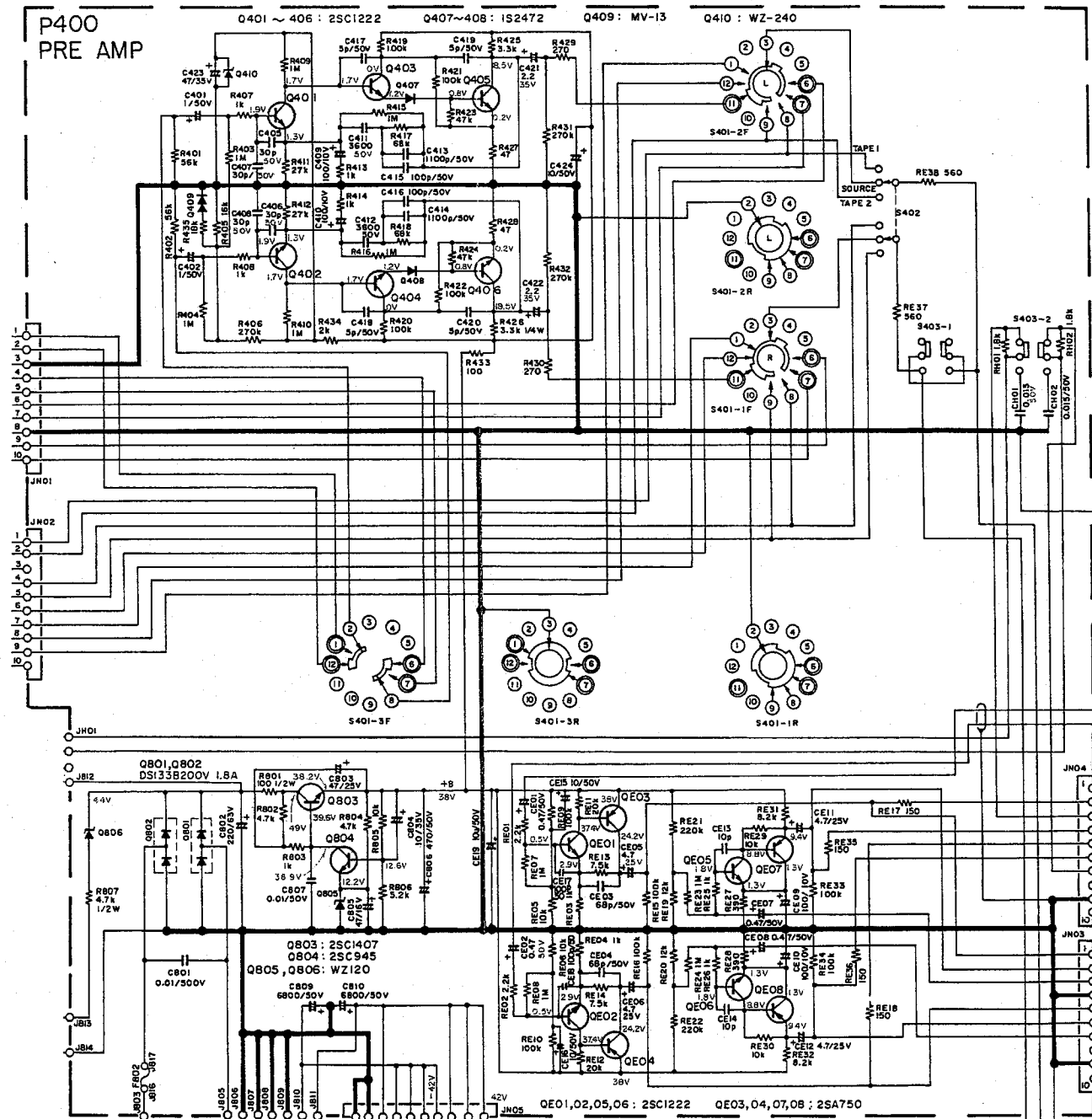

10.5 Main Amp. Assembly (P700) Schematic Diagram and Component Locations

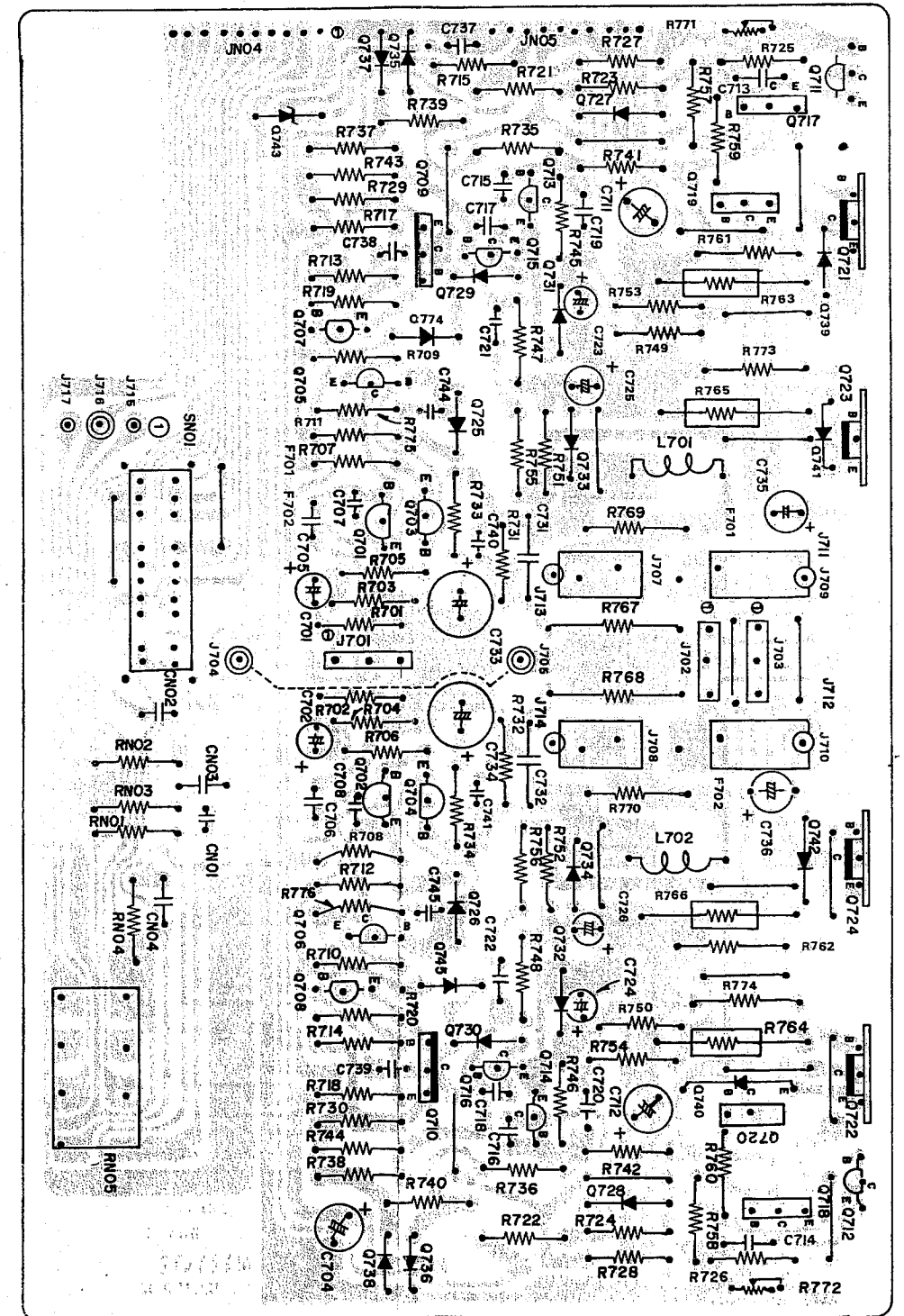
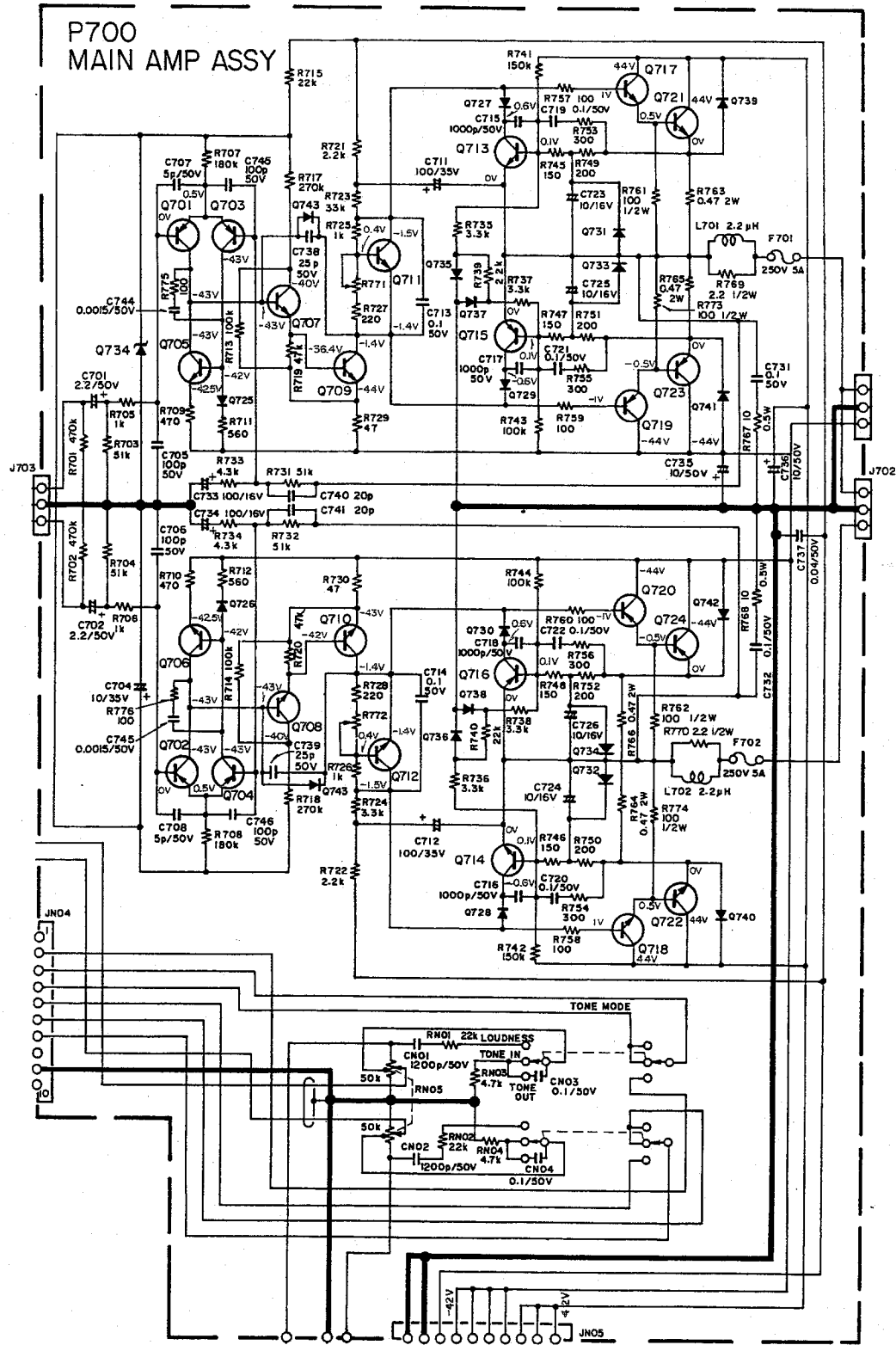

11. CONNECTION DIAGRAM

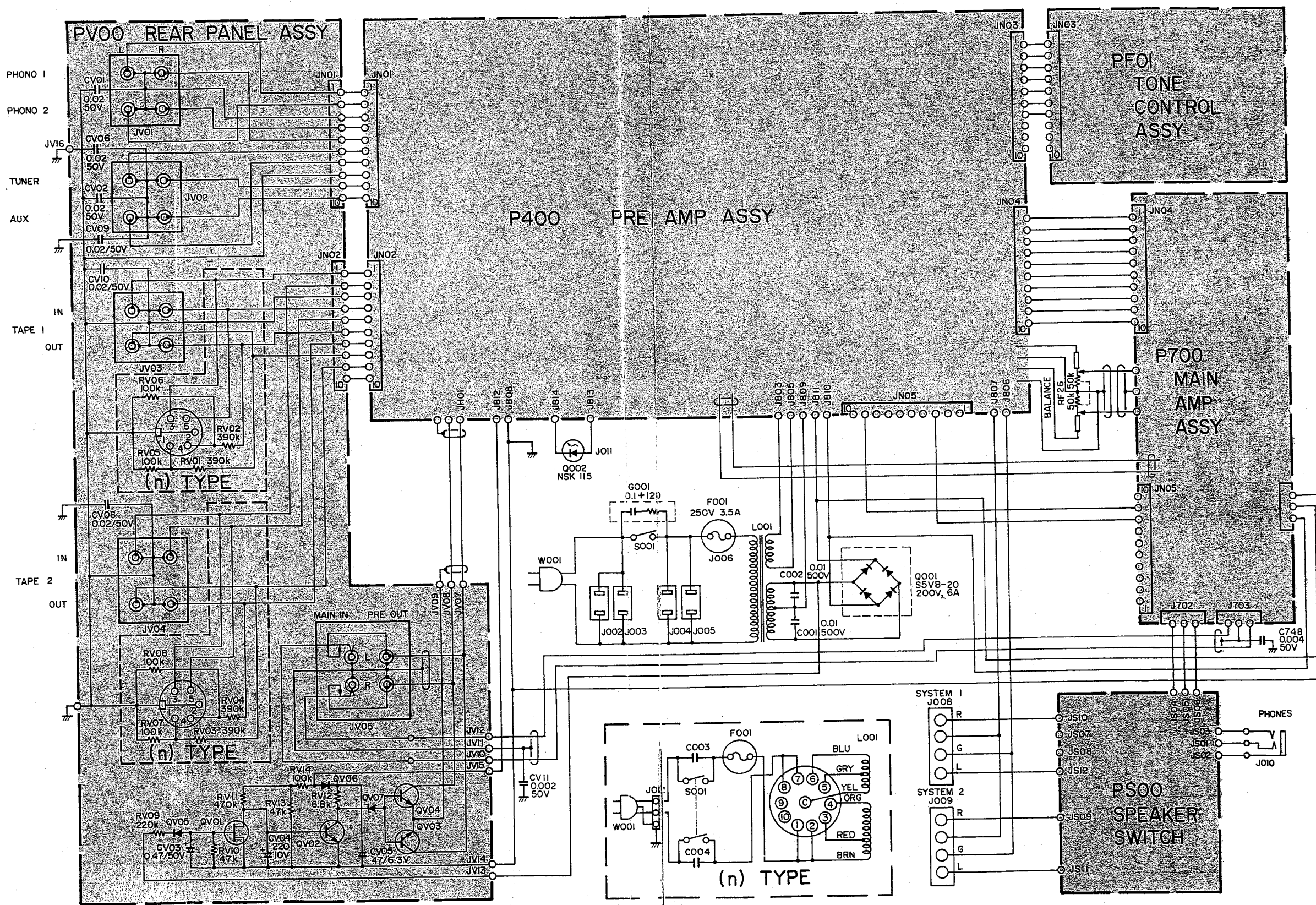

12. SCHEMATIC DIAGRAM

Model 1090

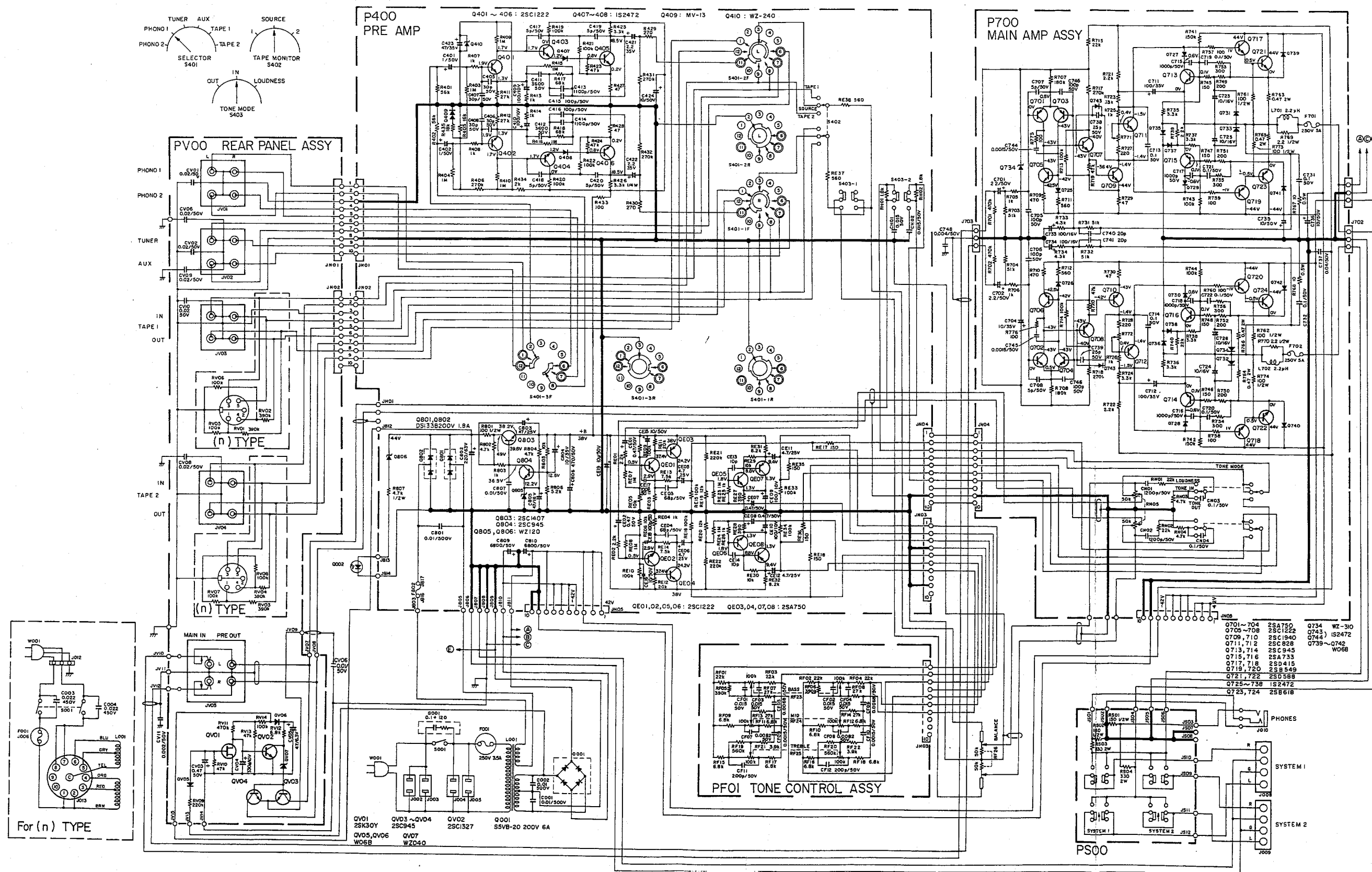

13. EXPLODED MECHANICAL DIAGRAM

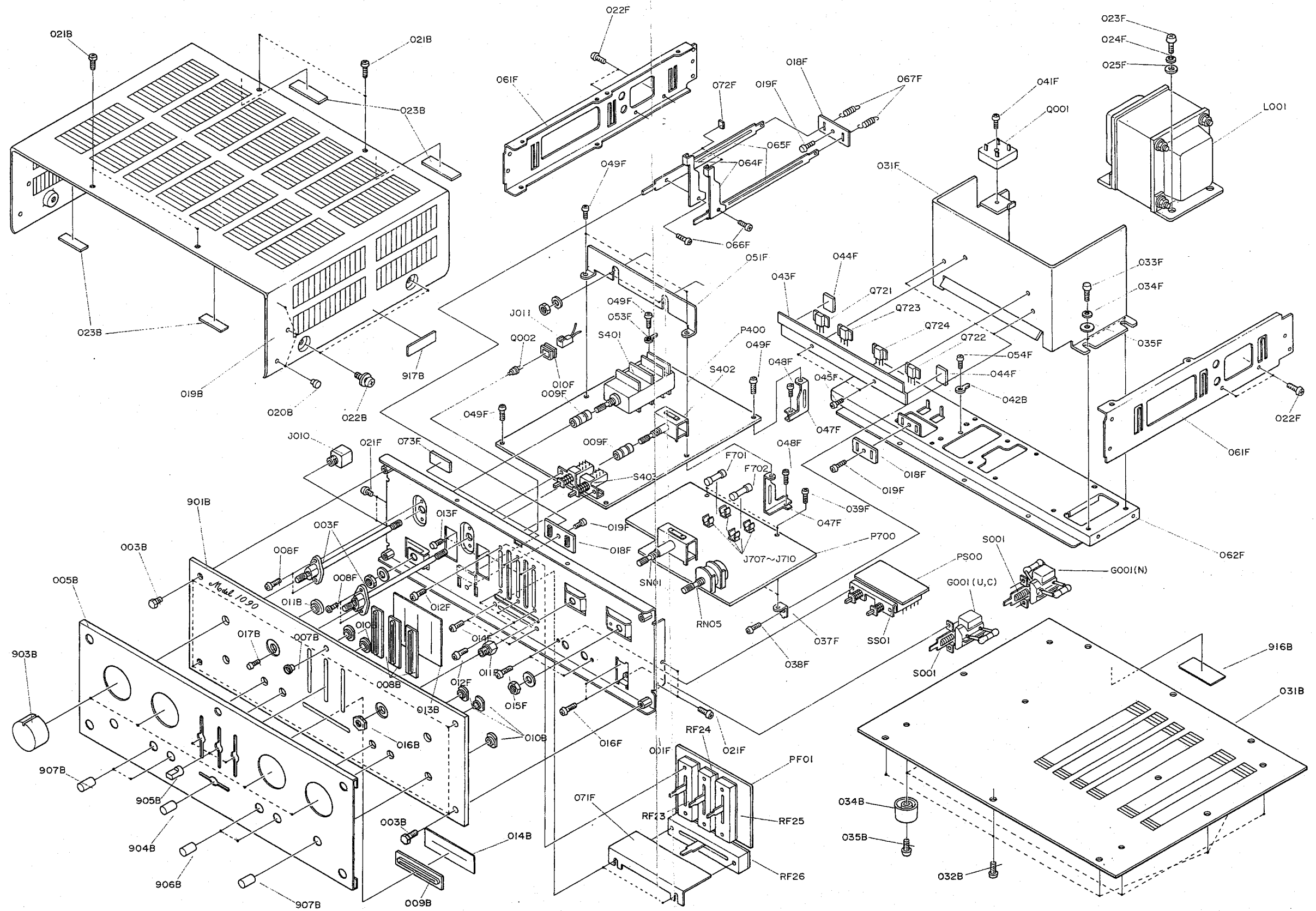

13.1 Rear Panel for U.S.A. & Canadian Model

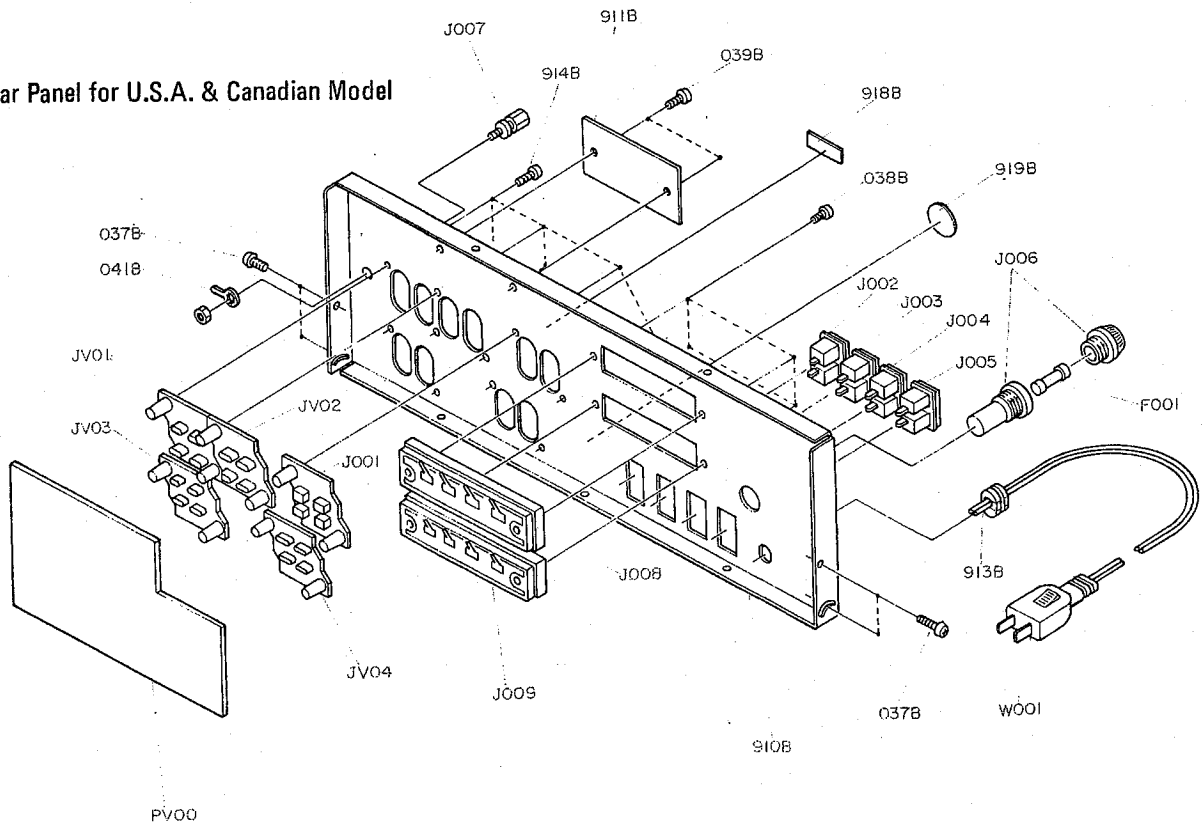

13.2 Rear Panel for European Model

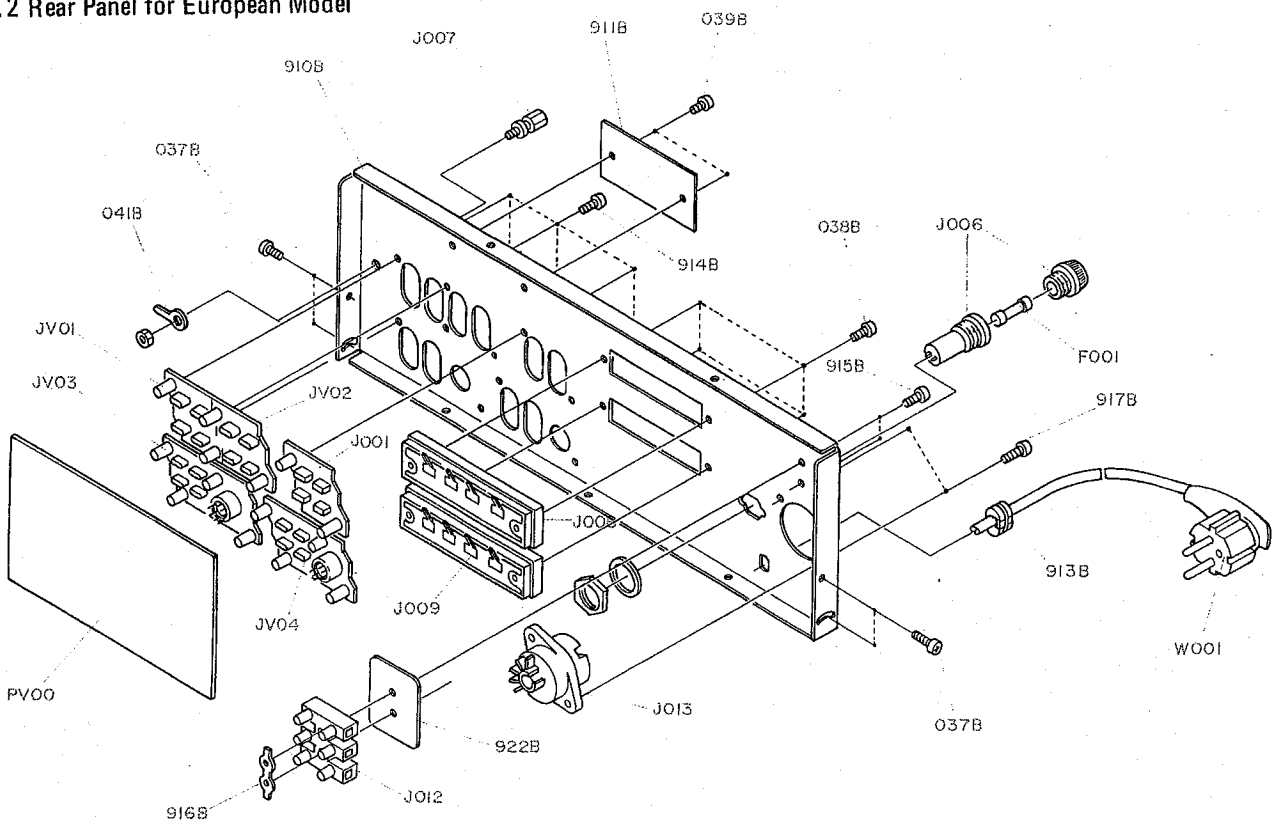

14. PACKING MATERIAL EXPLODED VIEW

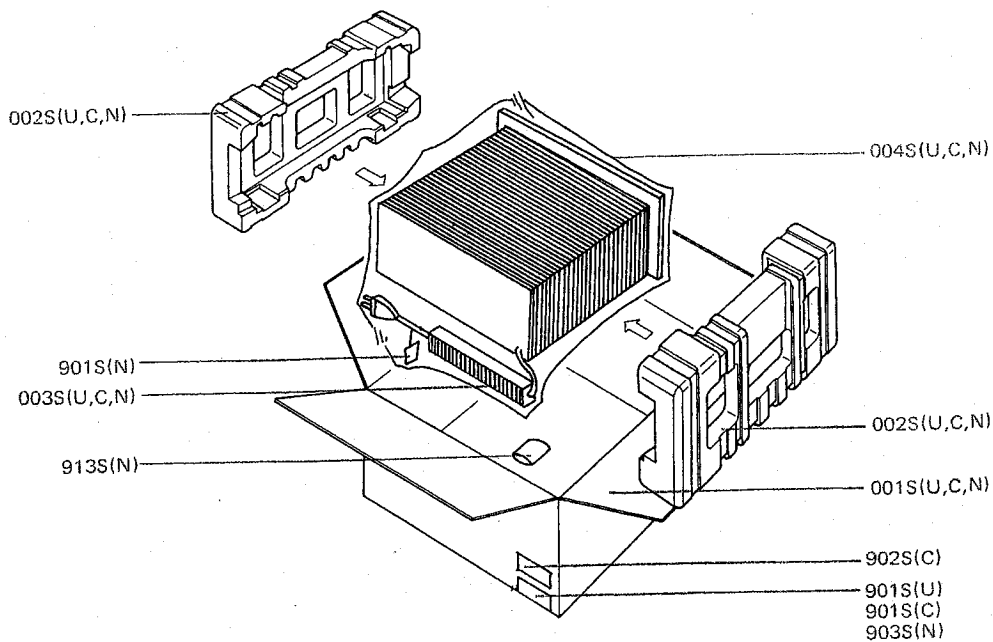
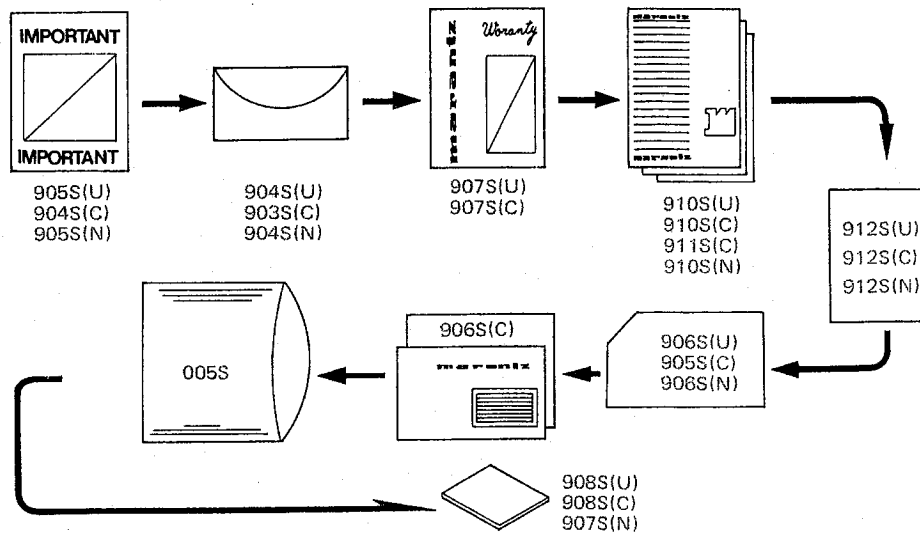

• (U) for U.S.A.
• (C) for Canada
• (N) for Europe

15. BLOCK DIAGRAM

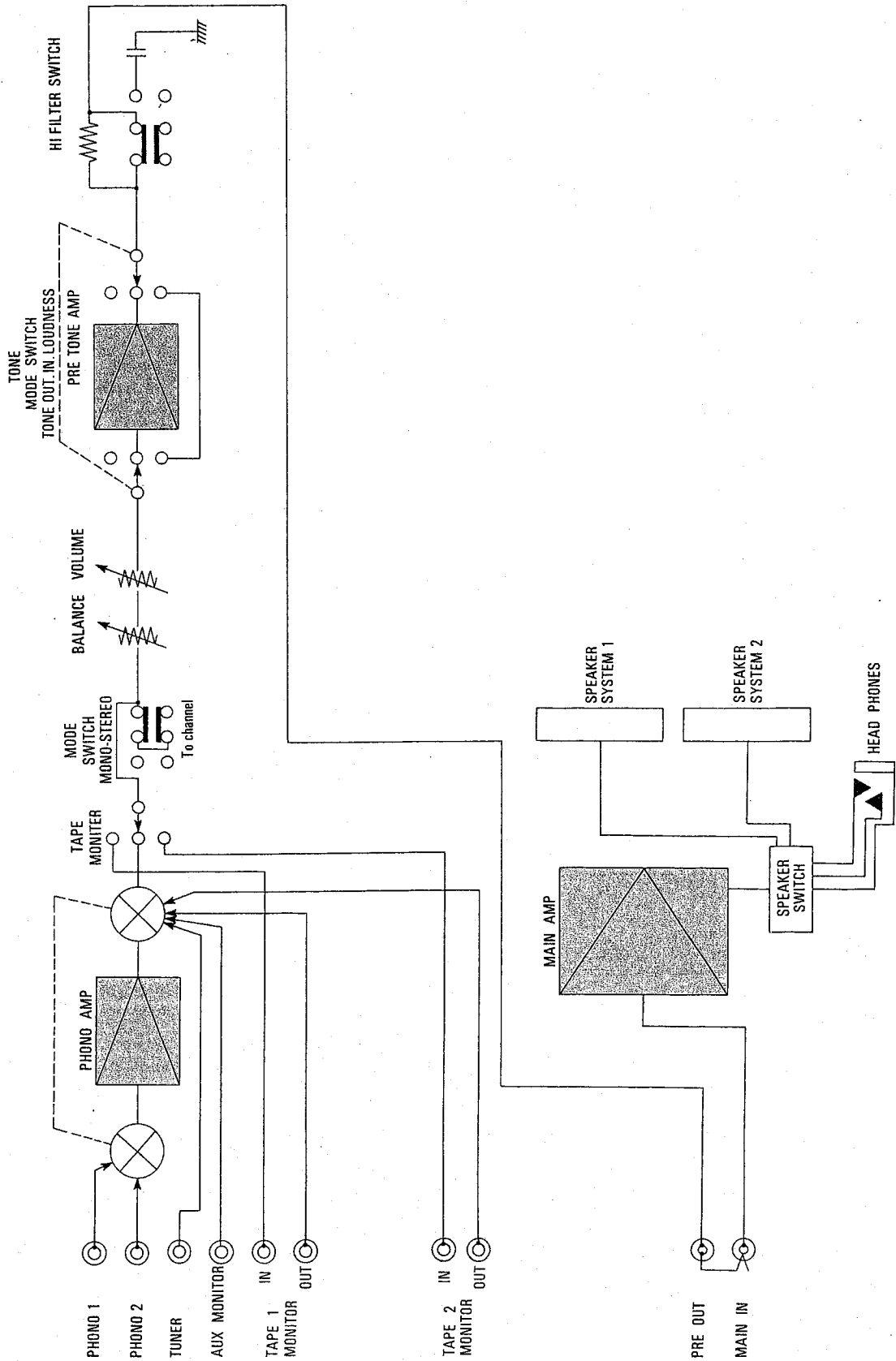

15. PARTS LIST

• (U) for U.S.A.
• (C) for Canada
• (N) for Europe

REF. DESIG.	Q'TY			PART NO.	DESCRIPTION
	U	C	N		
A	1	1	1	2231063400	Front Panel Assembly
005B	1	1	1	2231053010	Cover
007B	1	1	1	2979259020	Bushing
008B	3	3	3	2970259010	Bushing
009B	1	1	1	2926259042	Bushing
010B	5	5	5	2978259010	Bushing
011B	1	1	1	2978259020	Bushing
013B	1	1	1	2970303010	Mask
014B	1	1	1	2926303020	Mask
901B	1	1	1	2231063010	Escutcheon
B	1	1	1	2965257400	Lid Assembly, Upper
019B	1	1	1	2965257012	Lid
023B	4	4	4	2965118010	Spacer
PF11	1	1	1	75061251P0	Jumper
PS08	4	4	4	2933118020	Spacer
PV11	3	3	3	75061251P0	Jumper
P408	6	6	6	2933118020	Spacer
P411	37	37	37	75061251P0	Jumper
P708	20	20	20	2933118020	Spacer
P711	20	20	20	75061251P0	Jumper
P712	2	2	2	75061001P0	Jumper
001F	1	1	1	2231160012	Bracket
001S	1	1	1	2231801010	Packing Case
002S	2	2	2	2965809010	Cushion
003B	4	4	4	52017069J0	H. Head Bolt
003F	2	2	2	2231112510	Shaft
003S	1	1	1	2864804010	Sleeve
004S	1	1	1	9014335330	Polyethylene Bag
005S	1	1	1	9013025010	Polyethylene Bag
008F	4	4	4	51280308B0	B.H. Tapped Screw, B3 x 8
009F	2	2	2	2963125010	Joint
010F	1	1	1	2978259060	Bushing
011F	1	1	1	2231101010	Support
012F	6	6	6	51100306A9	B.H.M. Screw, B3 x 6
013F	2	2	2	51100306A9	B.H.M. Screw, B3 x 6
014F	2	2	2	51100306A9	B.H.M. Screw, B3 x 6
015F	2	2	2	51100306A9	B.H.M. Screw, B3 x 6
016B	1	1	1	53118179A0	Hexagon Nut
016F	2	2	2	51100306A9	B.H.M. Screw, B3 x 6
017B	1	1	1	51302608B0	P.H. Tapped Screw, P2.6 x 8
018F	2	2	2	2231259010	Bushing
019F	2	2	2	51300306B0	P.H. Tapped Screw, P3 x 6
020B	6	6	6	2979259030	Bushing
021B	4	4	4	51280306U0	B.H. Tapped Screw, B3 x 6
021F	4	4	4	51280306B0	B.H. Tapped Screw, B3 x 6
022B	4	4	4	51480406S9	F. Washer Screw
022F	4	4	4	51280306B0	B.H. Tapped Screw, B3 x 6
023F	4	4	4	51280410B0	B.H. Tapped Screw, B4 x 10

REF. DESIG.	Q'TY			PART NO.	DESCRIPTION
	U	C	N		
024F	4	4	4	54040402A0	Spring Washer
025F	4	4	4	54020401A0	Flat Washer, P.
031B	1	1	1	2231257010	Lid
031F	1	1	1	2231267010	Heatsink
032B	10	10	10	51280410U0	B.H. Tapped Screw, B4 x 10
033F	4	4	4	51280410B0	B.H. Tapped Screw, B4 x 10
034B	4	4	4	2932057010	Leg
034F	4	4	4	54040402A0	Spring Washer
035B	4	4	4	51570410S0	P. Tapped Screw, P4 x 10
035F	4	4	4	54020401A0	Flat Washer, P.
037B	4	4	4	51280306U0	B.H. Tapped Screw, B3 x 6
037F	2	2	2	2231160040	Bracket
038B	4	4	4	51280308U0	B.H. Tapped Screw, B3 x 8
038F	2	2	2	51280308B0	B.H. Tapped Screw, B3 x 8
039B	2	2	2	51760306B0	OS Tapped Screw, O3 x 6
039F	2	2	2	51280306B0	B.H. Tapped Screw, B3 x 6
041B	1	1	1	62040029W0	Lug
041F	1	1	1	51280310B0	B.H. Tapped Screw, B3 x 10
043F	1	1	1	2231005010	Clamper
044F	2	2	2	2231118010	Spacer
045F	2	2	2	51280310B0	B.H. Tapped Screw, B3 x 10
047F	2	2	2	2231104010	Retainer
048F	2	2	2	51280306B0	B.H. Tapped Screw, B3 x 6
049F	5	5	5	51280306B0	B.H. Tapped Screw, B3 x 6
051F	1	1	1	2231160032	Bracket
053F	1	1	1	62030039W0	Lug
061F	2	2	2	2231105010	Chassis
062F	1	1	1	2231105020	Chassis
064F	2	2	2	2231354010	Lever
065F	2	2	2	2231357010	Rod
066F	2	2	2	51280306B0	B.H. Tapped Screw, B3 x 6
067F	2	2	2	2231115010	Spring
901F			1	62030039W0	Lug
901S	3			9522815010	Serial No. Card
901S		3		9523015120	Serial No. Card
901S			1	9560000042	Hang Tag
902F			1	51280306B0	B.H. Tapped Screw, B3 x 6
902S		2		9510901020	Label
903B	4	4	4	2963154010	Knob
903S		1		2918813012	Envelope
903S			3	9523015130	Serial No. Card
904B	1	1	1	2970154012	Knob
904F			1	2882861020	Label
904S	1			2577813010	Envelope
904S			1	2818813010	Envelope
904S		1		2818851120	Instructions
905B	3	3	3	2970154023	Knob
905S	1			2577851020	Instructions
905S			1	2818851120	Instructions
905S		1		9630000180	Guarantee Card
906B	2	2	2	2970154032	Knob
906S	1			2577854012	Guarantee Card
906S			1	9630000180	Guarantee Card
906S		1		9650000050	S. Station Card
907B	3	3	3	2963154022	Knob
907S			1	2818851140	Instructions
907S	1			2818854023	Guarantee Card

- (U) for U.S.A.
- (C) for Canada
- (N) for Europe

REF. DESIG.	Q'TY			PART NO.	DESCRIPTION
	U	C	N		
907S	1			2818854042	Guarantee Card
908S	1			2818851040	Instructions
908S	1			2818854140	Guarantee Card
910B	1	1		2231160212	Bracket
910B	1		1	2231160223	Bracket
910S	1			2231851010	Instructions
910S	1		1	2231851310	Instructions
910S	1			2991851310	Instructions
911B	1			2231265012	Indicator
911B	1			2231265022	Indicator
911B			1	2231265030	Indicator
911S			1	2886851100	Instructions
913B	1	1		1455259030	Bushing
913B			1	1455259040	Bushing
913S			1	2731821010	Silicagel
914B	10	10	12	51280308U0	B.H. Tapped Screw, B3 x 8
915B			2	51100314S9	B.H.M. Screw, B3 x 14
916B	1			2578861010	Label
916B	1			2911861112	Label
916B	1			2970005010	Clamper
917B	1			2911861142	Label
917B	1			2932861010	Label
917B			2	51100308S9	B.H.M. Screw, B3 x 8
918B	1			9510911010	Label
918B	1			9510911020	Label
919B	1			2578861010	Label
919B	1			9511101010	Label
920B	1			2911861192	Label
920B	1			2932861010	Label
921B	1			2911861220	Label
921B			1	9510911070	Label
922B			1	4113120010	Insulator
CE01	1	1	1	EE47405040	Electrolytic Cap., 0.47μF 50V
CE02	1	1	1	EE47405040	Electrolytic Cap., 0.47μF 50V
CE03	1	1	1	DD16500010	Ceramic Cap., 50pF ±10% 50V
CE04	1	1	1	DD16500010	Ceramic Cap., 50pF ±10% 50V
CE05	1	1	1	EE47502540	Electrolytic Cap., 4.7μF 25V
CE06	1	1	1	EE47502540	Electrolytic Cap., 4.7μF 25V
CE07	1	1	1	EE47405040	Electrolytic Cap., 0.47μF 50V
CE08	1	1	1	EE47405040	Electrolytic Cap., 0.47μF 50V
CE09	1	1	1	EA10701090	Electrolytic Cap., 100μF 10V
CE10	1	1	1	EA10701090	Electrolytic Cap., 100μF 10V
CE11	1	1	1	EE47502540	Electrolytic Cap., 4.7μF 25V
CE12	1	1	1	EE47502540	Electrolytic Cap., 4.7μF 25V
CE13	1	1	1	DD12100010	Ceramic Cap., 10pF 50V
CE14	1	1	1	DD12100010	Ceramic Cap., 10pF 50V
CE15	1	1	1	EE10605040	Electrolytic Cap., 10μF 50V
CE16	1	1	1	EE10605040	Electrolytic Cap., 10μF 50V
CE17	1	1	1	DD15101020	Ceramic Cap., 100pF 50V
CE18	1	1	1	DD15101020	Ceramic Cap., 100pF 50V
CE19	1	1	1	EA10605090	Electrolytic Cap., 10μF 50V
QE01	1	1	1	HT312222B0	Transistor, 2SC1222 (E, U)
QE02	1	1	1	HT312222B0	Transistor, 2SC1222 (E, U)
QE03	1	1	1	HT107502A0	Transistor, 2SA750 (F, E)
QE04	1	1	1	HT107502A0	Transistor, 2SA750 (F, E)
QE05	1	1	1	HT312222B0	Transistor, 2SC1222 (E, U)
QE06	1	1	1	HT312222B0	Transistor, 2SC1222 (E, U)
QE07	1	1	1	HT107502A0	Transistor, 2SA750 (F, E)
QE08	1	1	1	HT107502A0	Transistor, 2SA750 (F, E)

REF. DESIG.	Q'TY			PART NO.	DESCRIPTION
	U	C	N		
RE01	1	1	1	RT05221140	Resistor, 220Ω ±5% ¼W
RE02	1	1	1	RT05221140	Resistor, 220Ω ±5% ¼W
RE03	1	1	1	RT05102140	Resistor, 1kΩ ±5% ¼W
RE04	1	1	1	RT05102140	Resistor, 1kΩ ±5% ¼W
RE05	1	1	1	RT05103140	Resistor, 10kΩ ±5% ¼W
RE06	1	1	1	RT05103140	Resistor, 10kΩ ±5% ¼W
RE07	1	1	1	RT05105140	Resistor, 1MΩ ±5% ¼W
RE08	1	1	1	RT05105140	Resistor, 1MΩ ±5% ¼W
RE09	1	1	1	RT05104140	Resistor, 100kΩ ±5% ¼W
RE10	1	1	1	RT05104140	Resistor, 100kΩ ±5% ¼W
RE11	1	1	1	RT05203140	Resistor, 20kΩ ±5% ¼W
RE12	1	1	1	RT05203140	Resistor, 20kΩ ±5% ¼W
RE13	1	1	1	RT05752140	Resistor, 7.5kΩ ±5% ¼W
RE14	1	1	1	RT05752140	Resistor, 7.5kΩ ±5% ¼W
RE15	1	1	1	RT05104140	Resistor, 100kΩ ±5% ¼W
RE16	1	1	1	RT05104140	Resistor, 100kΩ ±5% ¼W
RE17	1	1	1	RT05101140	Resistor, 100Ω ±5% ¼W
RE18	1	1	1	RT05101140	Resistor, 100Ω ±5% ¼W
RE19	1	1	1	RT05123140	Resistor, 12kΩ ±5% ¼W
RE20	1	1	1	RT05123140	Resistor, 12kΩ ±5% ¼W
RE21	1	1	1	RT05224140	Resistor, 220kΩ ±5% ¼W
RE22	1	1	1	RT05224140	Resistor, 220kΩ ±5% ¼W
RE23	1	1	1	RT05105140	Resistor, 1MΩ ±5% ¼W
RE24	1	1	1	RT05105140	Resistor, 1MΩ ±5% ¼W
RE25	1	1	1	RT05102140	Resistor, 1kΩ ±5% ¼W
RE26	1	1	1	RT05102140	Resistor, 1kΩ ±5% ¼W
RE27	1	1	1	RT05391140	Resistor, 390Ω ±5% ¼W
RE28	1	1	1	RT05391140	Resistor, 390Ω ±5% ¼W
RE29	1	1	1	RT05103140	Resistor, 10kΩ ±5% ¼W
RE30	1	1	1	RT05103140	Resistor, 10kΩ ±5% ¼W
RE31	1	1	1	RT05822140	Resistor, 8.2kΩ ±5% ¼W
RE32	1	1	1	RT05822140	Resistor, 8.2kΩ ±5% ¼W
RE33	1	1	1	RT05104140	Resistor, 100kΩ ±5% ¼W
RE34	1	1	1	RT05104140	Resistor, 100kΩ ±5% ¼W
RE35	1	1	1	RT05151140	Resistor, 150Ω ±5% ¼W
RE36	1	1	1	RT05151140	Resistor, 150Ω ±5% ¼W
RE37	1	1	1	RT05561140	Resistor, 560Ω ±5% ¼W
RE38	1	1	1	RT05561140	Resistor, 560Ω ±5% ¼W
CF01	1	1	1	DF16153010	Film Cap., 0.015μF ±10% 50V
CF02	1	1	1	DF16153010	Film Cap., 0.015μF ±10% 50V
CF03	1	1	1	DF16153010	Film Cap., 0.015μF ±10% 50V
CF04	1	1	1	DF16153010	Film Cap., 0.015μF ±10% 50V
CF05	1	1	1	DF16682010	Film Cap., 6800pF ±10% 50V
CF06	1	1	1	DF16682010	Film Cap., 6800pF ±10% 50V
CF07	1	1	1	DF16822010	Film Cap., 8200pF ±10% 50V
CF08	1	1	1	DF16822010	Film Cap., 8200pF ±10% 50V
CF09	1	1	1	DF16152010	Film Cap., 1500pF ±10% 50V
CF10	1	1	1	DF16152010	Film Cap., 1500pF ±10% 50V
CF11	1	1	1	DD16201010	Ceramic Cap., 200pF ±10% 50V
CF12	1	1	1	DD16201010	Ceramic Cap., 200pF ±10% 50V
JF01	1	1	1	YP06001040	Plug
PF01	1	1	1	YK22310210	P.W. Board
	1	1	1	ZZ22310210	P.W. Board Assembly
RF01	1	1	1	RT05183140	Resistor, 22kΩ ±5% ¼W
RF02	1	1	1	RT05183140	Resistor, 22kΩ ±5% ¼W
RF03	1	1	1	RT05183140	Resistor, 22kΩ ±5% ¼W
RF04	1	1	1	RT05183140	Resistor, 22kΩ ±5% ¼W
RF07	1	1	1	RT05273140	Resistor, 27kΩ ±5% ¼W

- (U) for U.S.A.
- (C) for Canada
- (N) for Europe

REF. DESIG.	Q'TY			PART NO.	DESCRIPTION
	U	C	N		
RF08	1	1	1	RT05273140	Resistor, 27kΩ ±5% ¼W
RF09	1	1	1	RT05562140	Resistor, 6.8kΩ ±5% ¼W
RF10	1	1	1	RT05562140	Resistor, 6.8kΩ ±5% ¼W
RF11	1	1	1	RT05682140	Resistor, 6.8kΩ ±5% ¼W
RF12	1	1	1	RT05682140	Resistor, 6.8kΩ ±5% ¼W
RF13	1	1	1	RT05273140	Resistor, 27kΩ ±5% ¼W
RF14	1	1	1	RT05273140	Resistor, 27kΩ ±5% ¼W
RF15	1	1	1	RT05682140	Resistor, 6.8kΩ ±5% ¼W
RF16	1	1	1	RT05682140	Resistor, 6.8kΩ ±5% ¼W
RF17	1	1	1	RT05682140	Resistor, 6.8kΩ ±5% ¼W
RF18	1	1	1	RT05682140	Resistor, 6.8kΩ ±5% ¼W
RF19	1	1	1	RT05564140	Resistor, 560kΩ ±5% ¼W
RF20	1	1	1	RT05564140	Resistor, 560kΩ ±5% ¼W
RF21	1	1	1	RT05392140	Resistor, 3.9kΩ ±5% ¼W
RF22	1	1	1	RT05392140	Resistor, 3.9kΩ ±5% ¼W
RF23	1	1	1	RS01040050	Variable Resistor, 100kΩ X2 B
RF24	1	1	1	RS01040050	Variable Resistor, 100kΩ X2 B
RF25	1	1	1	RS01040050	Variable Resistor, 100kΩ X2 B
RF26	1	1	1	RS05030330	Variable Resistor, 50kΩ X2 B
CH01	1	1	1	DF16153010	Film Cap., 0.015μF ±10% 50V
CH02	1	1	1	DF16153010	Film Cap., 0.015μF ±10% 50V
RH01	1	1	1	RT05202140	Resistor, 2kΩ ±5% ¼W
RH02	1	1	1	RT05202140	Resistor, 2kΩ ±5% ¼W
CN01	1	1	1	DF16122010	Film Cap., 1200pF ±10% 50V
CN02	1	1	1	DF16122010	Film Cap., 1200pF ±10% 50V
CN03	1	1	1	DF17104010	Film Cap., 0.1μF ±20% 50V
CN04	1	1	1	DF17104010	Film Cap., 0.1μF ±20% 50V
JN01	1	1	1	YU10070010	Connective Cord
JN02	1	1	1	YU10070010	Connective Cord
JN04	1	1	1	YU10070010	Connective Cord
RN01	1	1	1	RT05223140	Resistor, 22kΩ ±5% ¼W
RN02	1	1	1	RT05223140	Resistor, 22kΩ ±5% ¼W
RN03	1	1	1	RT05472140	Resistor, 4.7kΩ ±5% ¼W
RN04	1	1	1	RT05472140	Resistor, 4.7kΩ ±5% ¼W
RN05	1	1	1	RM05030680	Variable Resistor, 50kΩ X2 B
SN01	1	1	1	SR04030170	Rotary Switch
JS01	1	1	1	YP10001130	Plug
JS09	9	9	9	YP10001130	Plug
PS01	1	1	1	YK22311220	P.W. Board
	1	1	1	ZZ22311220	P.W. Board Assembly
RS01	1	1	1	GF05151120	Resistor, 150Ω ±5% ¼W
RS02	1	1	1	GF05151120	Resistor, 150Ω ±5% ¼W
RS03	1	1	1	GJ05331020	Resistor, 330Ω ±5% 2W
RS04	1	1	1	GJ05331020	Resistor, 330Ω ±5% 2W
SS01	1	1	1	SP04020220	Pushswitch, Spkr Switch
CV01	1	1	1	DK18203020	Ceramic Cap., 0.02μF ±20% 50V
CV02	1	1	1	DK18203020	Ceramic Cap., 0.02μF ±20% 50V
CV03	1	1	1	EA47405090	Electrolytic Cap., 0.47μF 50V
CV04	1	1	1	EA33701090	Electrolytic Cap., 330μF 10V
CV05	1	1	1	EA47606390	Electrolytic Cap., 47μF 63V
CV06	1	1	1	DK18203200	Ceramic Cap., 0.02μF 50V
CV07	1	1	1	DK18203200	Ceramic Cap., 0.02μF 50V
CV08	1	1	1	DK18203200	Ceramic Cap., 0.02μF 50V
CV09	1	1	1	DK18203200	Ceramic Cap., 0.02μF 50V

REF. DESIG.	Q'TY			PART NO.	DESCRIPTION
	U	C	N		
JV01	1	1	1	YT02040150	Terminal, 4P Phono
JV02	1	1	1	YT02040150	Terminal, 4P Tuner Aux
JV03	1	1	1	BY01050060	Jack, (DIN)
JV03	1	1	1	YT02040150	Terminal, 4P Tape 1
JV04	1	1	1	BY01050060	Jack, (DIN)
JV04	1	1	1	YT02040150	Terminal, 4P Tape 2
JV05	1	1	1	YT02040210	Terminal, 4P Pre Out
JV06	1	1	1	YP10001130	Plug
JV16	1	1	1	YP10001130	Plug
PV00	1	1	1	YK22311210	PV00 REAR PANEL BOARD
	1	1	1	ZZ22311210	P.W. Board
			1	ZZ22318210	P.W. Board Assembly
QV01	1	1	1	HF200301C0	F.E.T., 2SK30 Y
QV02	1	1	1	HT309452A0	Transistor, 2SC945 (Q, R)
QV03	1	1	1	HT309452A0	Transistor, 2SC945 (Q, R)
QV04	1	1	1	HT309452A0	Transistor, 2SC945 (Q, R)
QV05	1	1	1	HD20005010	Diode, W06B
QV06	1	1	1	HD20005010	Diode, W06B
QV07	1	1	1	HD30033090	Zener, WZ-052 5.2V
RV01	1	1	1	GD05394140	Resistor, 390kΩ ±5% ¼W
RV02	1	1	1	GD05394140	Resistor, 390kΩ ±5% ¼W
RV03	1	1	1	GD05394140	Resistor, 390kΩ ±5% ¼W
RV04	1	1	1	GD05394140	Resistor, 390kΩ ±5% ¼W
RV05	1	1	1	GD05104140	Resistor, 100kΩ ±5% ¼W
RV06	1	1	1	GD05104140	Resistor, 100kΩ ±5% ¼W
RV07	1	1	1	GD05104140	Resistor, 100kΩ ±5% ¼W
RV08	1	1	1	GD05104140	Resistor, 100kΩ ±5% ¼W
RV09	1	1	1	GD05224140	Resistor, 220kΩ ±5% ¼W
RV10	1	1	1	GD05473140	Resistor, 47kΩ ±5% ¼W
RV11	1	1	1	GD05564140	Resistor, 560kΩ ±5% ¼W
RV12	1	1	1	GD05682140	Resistor, 6.8kΩ ±5% ¼W
RV13	1	1	1	GD05473140	Resistor, 47kΩ ±5% ¼W
RV14	1	1	1	GD05104140	Resistor, 100kΩ ±5% ¼W
C001	1	1	1	DK18103510	Ceramic Cap., 0.01μF ±20% 500V
C002	1	1	1	DK18103510	Ceramic Cap., 0.01μF ±20% 500V
C003	1	1	1	DD07223510	Oil-Paper Cap., 0.022μF 450VAC
C004	1	1	1	DD07223510	Oil-Paper Cap., 0.022μF 450VAC
F001	1	1	1	FS10350010	Fuse, 3.5A MGC U
F001	1	1	1	FS10350800	Fuse, 3.5A T SEMK
G001	1	1	1	BF10400030	Cap. Comp.
G001	1	1	1	BF33300020	Cap. Comp.
J002	1	1	1	YJ04000560	Jack, AC Outlet
J003	1	1	1	YJ04000560	Jack, AC Outlet
J004	1	1	1	YJ04000560	Jack, AC Outlet
J005	1	1	1	YJ04000560	Jack, AC Outlet
J006	1	1	1	YJ08000120	Jack, Fuse Holder (30mm)
J006	1	1	1	YJ08000220	Jack, Fuse Holder (20mm)
J007	1	1	1	YT01010050	Terminal, Ground
J008	1	1	1	YT03040160	Terminal, Speaker
J009	1	1	1	YT03040160	Terminal, Speaker
J010	1	1	1	YJ01000650	Jack, Headphone Terminal
J011	1	1	1	YJ05000250	Jack, LED Socket
J012	1	1	1	YL09030010	Terminal, 3P AC Terminal
J013	1	1	1	BY03110010	Plug, Voltage Selector

- (U) for U.S.A.
- (C) for Canada
- (N) for Europe

REF. DESIG.	QTY			PART NO.	DESCRIPTION
	U	C	N		
L001	1	1		TS18607010	Power Transformer
L001			1	TS18607020	Power Transformer
Q001	1	1	1	HD20004290	Diode, S5VB-20
Q002	1	1	1	HI10004030	L.E.D. 132B
S001	1	1		SP01010200	Pushswitch
S001			1	SP02010300	Pushswitch, Power, SEMKO JP24
W001			1	YC01900030	AC Power Cord
W001	1	1		YC02400220	AC Power Cord
C401	1	1	1	EE47502540	Electrolytic Cap., 1μF 50V
C402	1	1	1	EE47502540	Electrolytic Cap., 1μF 50V
C405	1	1	1	DD16300010	Ceramic Cap., 30pF ±10% 50V
C406	1	1	1	DD16300010	Ceramic Cap., 30pF ±10% 50V
C407	1	1	1	DD16300010	Ceramic Cap., 30pF ±10% 50V
C408	1	1	1	DD16300010	Ceramic Cap., 30pF ±10% 50V
C409	1	1	1	EA10701090	Electrolytic Cap., 100μF 10V
C410	1	1	1	EA10701090	Electrolytic Cap., 100μF 10V
C411	1	1	1	DF14362010	Film Cap., 3600pF ±5% 50V
C412	1	1	1	DF14362010	Film Cap., 3600pF ±5% 50V
C413	1	1	1	DF14112010	Film Cap., 1100pF ±5% 50V
C414	1	1	1	DF14112010	Film Cap., 1100pF ±5% 50V
C415	1	1	1	DD15101020	Ceramic Cap., 100pF ±5% 50V
C416	1	1	1	DD15101020	Ceramic Cap., 100pF ±5% 50V
C417	1	1	1	DD12050010	Ceramic Cap., 5pF ±1pF 50V
C418	1	1	1	DD12050010	Ceramic Cap., 5pF ±1pF 50V
C419	1	1	1	DD12050010	Ceramic Cap., 5pF ±1pF 50V
C420	1	1	1	DD12050010	Ceramic Cap., 5pF ±1pF 50V
C421	1	1	1	EE47502540	Electrolytic Cap., 2.2μF 25V
C422	1	1	1	EE47502540	Electrolytic Cap., 2.2μF 25V
C424	1	1	1	EA10603590	Electrolytic Cap., 10μF 50V
P400	1	1	1	YG22310010	P400 PHONO, TONE & SELECTOR BOARD P.W. Board
			1	ZZ22310010	P.W. Board Assembly
			1	ZZ22319010	P.W. Board Assembly
			1	ZZ22318010	P.W. Board Assembly
Q401	1	1	1	HT312222B0	Transistor, 2SC1222 (E, U)
Q402	1	1	1	HT312222B0	Transistor, 2SC1222 (E, U)
Q403	1	1	1	HT312222B0	Transistor, 2SC1222 (E, U)
Q404	1	1	1	HT312222B0	Transistor, 2SC1222 (E, U)
Q405	1	1	1	HT312222B0	Transistor, 2SC1222 (E, U)
Q406	1	1	1	HT312222B0	Transistor, 2SC1222 (E, U)
Q407	1	1	1	HD20002210	Diode, 1S2472
Q408	1	1	1	HD20002210	Diode, 1S2472
Q409	1	1	1		Diode, MV-13
R401	1	1	1	RT05563140	Resistor, 56kΩ ±5% ¼W
R402	1	1	1	RT05563140	Resistor, 56kΩ ±5% ¼W
R403	1	1	1	RT05105140	Resistor, 1MΩ ±5% ¼W
R404	1	1	1	RT05105140	Resistor, 1MΩ ±5% ¼W
R405	1	1	1	RT05163140	Resistor, 16kΩ ±5% ¼W
R406	1	1	1	RT05274140	Resistor, 270kΩ ±5% ¼W
R407	1	1	1	RT05102140	Resistor, 1kΩ ±5% ¼W
R408	1	1	1	RT05102140	Resistor, 1kΩ ±5% ¼W
R409	1	1	1	RT05105140	Resistor, 1MΩ ±5% ¼W
R410	1	1	1	RT05105140	Resistor, 1MΩ ±5% ¼W
R411	1	1	1	RT05273140	Resistor, 27kΩ ±5% ¼W
R412	1	1	1	RT05273140	Resistor, 27kΩ ±5% ¼W

REF. DESIG.	QTY			PART NO.	DESCRIPTION
	U	C	N		
R413	1	1	1	RT02102140	Resistor, 1kΩ ±5% ¼W
R414	1	1	1	RT02102140	Resistor, 1kΩ ±5% ¼W
R415	1	1	1	RT05105140	Resistor, 1MΩ ±5% ¼W
R416	1	1	1	RT05105140	Resistor, 1MΩ ±5% ¼W
R417	1	1	1	RT02683140	Resistor, 68kΩ ±5% ¼W
R418	1	1	1	RT02683140	Resistor, 68kΩ ±5% ¼W
R419	1	1	1	RT05104140	Resistor, 100kΩ ±5% ¼W
R420	1	1	1	RT05104140	Resistor, 100kΩ ±5% ¼W
R421	1	1	1	RT05104140	Resistor, 100kΩ ±5% ¼W
R422	1	1	1	RT05104140	Resistor, 100kΩ ±5% ¼W
R423	1	1	1	RT05473140	Resistor, 47kΩ ±5% ¼W
R424	1	1	1	RT05473140	Resistor, 47kΩ ±5% ¼W
R425	1	1	1	RT05332140	Resistor, 3.3kΩ ±5% ¼W
R426	1	1	1	RT05332140	Resistor, 3.3kΩ ±5% ¼W
R427	1	1	1	RT05470140	Resistor, 47Ω ±5% ¼W
R428	1	1	1	RT05470140	Resistor, 47Ω ±5% ¼W
R429	1	1	1	RT05027140	Resistor, 270Ω ±5% ¼W
R430	1	1	1	RT05027140	Resistor, 270Ω ±5% ¼W
R431	1	1	1	RT05274140	Resistor, 270kΩ ±5% ¼W
R432	1	1	1	RT05274140	Resistor, 270kΩ ±5% ¼W
R433	1	1	1	GF05101140	Resistor, 100Ω ±5% ¼W
R435	1	1	1	RT05183140	Resistor, 18kΩ ±5% ¼W
S401	1	1	1	SR08060240	Rotary Switch
S402	1	1	1	SR04030170	Rotary (Slide) Switch
S403	1	1	1	SP02020310	Pushswitch
C701	1	1	1	EE22505040	Electrolytic Cap., 2.2μF 50V
C702	1	1	1	EE22505040	Electrolytic Cap., 2.2μF 50V
C703	1	1	1	EA47603590	Electrolytic Cap., 47μF 35V
C704	1	1	1	EA47603590	Electrolytic Cap., 47μF 35V
C705	1	1	1	DD16500010	Ceramic Cap., 100pF ±10% 50V
C706	1	1	1	DD16500010	Ceramic Cap., 100pF ±10% 50V
C707	1	1	1	DD12050010	Ceramic Cap., 5pF ±10% 50V
C708	1	1	1	DD12050010	Ceramic Cap., 5pF ±10% 50V
C711	1	1	1	EA10703590	Electrolytic Cap., 100μF 35V
C712	1	1	1	EA10703590	Electrolytic Cap., 100μF 35V
C713	1	1	1	DK18104020	Ceramic Cap., 0.1μF 25V
C714	1	1	1	DK18104020	Ceramic Cap., 0.1μF 25V
C715	1	1	1	DK17102010	Ceramic Cap., 1000pF ±20% 50V
C716	1	1	1	DK17102010	Ceramic Cap., 1000pF ±20% 50V
C717	1	1	1	DK17102010	Ceramic Cap., 1000pF ±20% 50V
C718	1	1	1	DK17102010	Ceramic Cap., 1000pF ±20% 50V
C719	1	1	1	DF17104010	Film Cap., 0.1μF ±20% 50V
C720	1	1	1	DF17104010	Film Cap., 0.1μF ±20% 50V
C721	1	1	1	DF17104010	Film Cap., 0.1μF ±20% 50V
C722	1	1	1	DF17104010	Film Cap., 0.1μF ±20% 50V
C723	1	1	1	EE10601640	Electrolytic Cap., 10μF 16V
C724	1	1	1	EE10601640	Electrolytic Cap., 10μF 16V
C725	1	1	1	EE10601640	Electrolytic Cap., 10μF 16V
C726	1	1	1	EE10601640	Electrolytic Cap., 10μF 16V
C735	1	1	1	EA10605400	Electrolytic Cap., 10μF 50V
C736	1	1	1	EA10605400	Electrolytic Cap., 10μF 50V
C740	1	1	1	DD16200010	Ceramic Cap., 20pF 50V
C741	1	1	1	DD16200010	Ceramic Cap., 20pF 50V
C744	1	1	1	DF16152010	Film Cap., 0.015μF 50V
C745	1	1	1	DF16152010	Film Cap., 0.015μF 50V
C738	1	1	1	DD16250010	Ceramic Cap., 25pF 50V
C739	1	1	1	DD16250010	Ceramic Cap., 25pF 50V
Q743	1	1	1	HD20002210	Diode, 1S2472
Q744	1	1	1	HD20002210	Diode, 1S2472

• (U) for U.S.A.
 • (C) for Canada
 • (N) for Europe

REF. DESIG.	Q'TY			PART NO.	DESCRIPTION
	U	C	N		
C735	1	1	1	EA10606900	Electrolytic Cap., 10μF 50V
C736	1	1	1	EA10606900	Electrolytic Cap., 10μF 50V
C737	1	1	1	DK18403010	Ceramic Cap., 0.04μF 50V
F701	1	1	1	FS10500040	Fuse, 5A MGC UL
F701	1	1	1	FS10500800	Fuse, 5A T SEMKO
F702	1	1	1	FS10500040	Fuse, 5A MGC UL
F702	1	1	1	FS10500800	Fuse, 5A T SEMKO
J701	1	1	1	YP06001040	Plug, Connector
J702	1	1	1	YP06001040	Plug, Connector
J703	1	1	1	YP06001040	Plug, Connector
J707	1	1	1	YJ08000210	Jack, Fuse Socket
J708	1	1	1	YJ08000210	Jack, Fuse Socket
J709	1	1	1	YJ08000210	Jack, Fuse Socket
J710	1	1	1	YJ08000210	Jack, Fuse Socket
L701	1	1	1	LL23915120	Choke Coil
L702	1	1	1	LL23915120	Choke Coil
P700 MAIN AMP BOARD					
P700	1	1	1	YG22310020	P.W. Board
	1	1	1	ZZ22310020	P.W. Board Assembly
Q701	1	1	1	HT107501E0	Transistor, 2SA750 (E)
Q702	1	1	1	HT107501E0	Transistor, 2SA750 (E)
Q703	1	1	1	HT107501E0	Transistor, 2SA750 (E)
Q704	1	1	1	HT107501E0	Transistor, 2SA750 (E)
Q705	1	1	1	HT312222B0	Transistor, 2SC1222 (E, U)
Q706	1	1	1	HT312222B0	Transistor, 2SC1222 (E, U)
Q707	1	1	1	HT312222B0	Transistor, 2SC1222 (E, U)
Q708	1	1	1	HT312222B0	Transistor, 2SC1222 (E, U)
Q709	1	1	1	HT319402B0	Transistor, 2SC1940 (L, K)
Q710	1	1	1	HT319402B0	Transistor, 2SC1940 (L, K)
Q711	1	1	1	HT308281E0	Transistor, 2SC828 (T)
Q712	1	1	1	HT308281E0	Transistor, 2SC828 (T)
Q713	1	1	1	HT309452A0	Transistor, 2SC945 (Q, R)
Q714	1	1	1	HT309452A0	Transistor, 2SC945 (Q, R)
Q715	1	1	1	HT107332A0	Transistor, 2SA733 (P, Q)
Q716	1	1	1	HT107332A0	Transistor, 2SA733 (P, Q)
Q717	1	1	1	HT404152A0	Transistor, 2SD415 (P, Q)
Q718	1	1	1	HT404152A0	Transistor, 2SD415 (P, Q)
Q719	1	1	1	HT205492A0	Transistor, 2SB549 (P, Q)
Q720	1	1	1	HT205492A0	Transistor, 2SB549 (P, Q)
Q721	1	1	1	HT405882B0	Transistor, 2SD588 (Q, R)
Q722	1	1	1	HT405882B0	Transistor, 2SD588 (Q, R)
Q723	1	1	1	HT206182B0	Transistor, 2SB618 (R, Q)
Q724	1	1	1	HT206182B0	Transistor, 2SB618 (R, Q)
Q725	1	1	1	HD20002210	Diode, 1S2472
Q726	1	1	1	HD20002210	Diode, 1S2472
Q727	1	1	1	HD20002210	Diode, 1S2472
Q728	1	1	1	HD20002210	Diode, 1S2472
Q729	1	1	1	HD20002210	Diode, 1S2472
Q730	1	1	1	HD20002210	Diode, 1S2472
Q731	1	1	1	HD20002210	Diode, 1S2472
Q732	1	1	1	HD20002210	Diode, 1S2472
Q733	1	1	1	HD20002210	Diode, 1S2472
Q734	1	1	1	HD20002210	Diode, 1S2472
Q735	1	1	1	HD20002210	Diode, 1S2472
Q736	1	1	1	HD20002210	Diode, 1S2472
Q737	1	1	1	HD20002210	Diode, 1S2472

REF. DESIG.	Q'TY			PART NO.	DESCRIPTION
	U	C	N		
Q738	1	1	1	HD20002210	Diode, 1S2472
Q739	1	1	1	HD20005010	Diode, W06B
Q740	1	1	1	HD20005010	Diode, W06B
Q741	1	1	1	HD20005010	Diode, W06B
Q742	1	1	1	HD20005010	Diode, W06B
R701	1	1	1	RT05474140	Resistor, 470kΩ ±5% ¼W
R702	1	1	1	RT05474140	Resistor, 470kΩ ±5% ¼W
R703	1	1	1	RT05513140	Resistor, 51kΩ ±5% ¼W
R704	1	1	1	RT05513140	Resistor, 51kΩ ±5% ¼W
R705	1	1	1	RT05102140	Resistor, 1kΩ ±5% ¼W
R706	1	1	1	RT05102140	Resistor, 1kΩ ±5% ¼W
R707	1	1	1	RT05473140	Resistor, 47kΩ ±5% ¼W
R708	1	1	1	RT05184140	Resistor, 47kΩ ±5% ¼W
R709	1	1	1	RT05471140	Resistor, 470Ω ±5% ¼W
R710	1	1	1	RT05471140	Resistor, 470Ω ±5% ¼W
R711	1	1	1	RT05561140	Resistor, 560Ω ±5% ¼W
R712	1	1	1	RT05561140	Resistor, 560Ω ±5% ¼W
R713	1	1	1	RT05104140	Resistor, 100kΩ ±5% ¼W
R714	1	1	1	RT05104140	Resistor, 100kΩ ±5% ¼W
R715	1	1	1	RT05332140	Resistor, 3.3kΩ ±5% ¼W
R717	1	1	1	RT05274140	Resistor, 270kΩ ±5% ¼W
R718	1	1	1	RT05274140	Resistor, 270kΩ ±5% ¼W
R719	1	1	1	RT05473140	Resistor, 47kΩ ±5% ¼W
R720	1	1	1	RT05473140	Resistor, 47kΩ ±5% ¼W
R721	1	1	1	RT05222140	Resistor, 2.2kΩ ±5% ¼W
R722	1	1	1	RT05222140	Resistor, 2.2kΩ ±5% ¼W
R723	1	1	1	RT05332140	Resistor, 3.3kΩ ±5% ¼W
R724	1	1	1	RT05332140	Resistor, 3.3kΩ ±5% ¼W
R725	1	1	1	RT05102140	Resistor, 1kΩ ±5% ¼W
R726	1	1	1	RT05102140	Resistor, 1kΩ ±5% ¼W
R727	1	1	1	RT05221140	Resistor, 220Ω ±5% ¼W
R728	1	1	1	RT05221140	Resistor, 220Ω ±5% ¼W
R729	1	1	1	RT05470140	Resistor, 47Ω ±5% ¼W
R730	1	1	1	RT05470140	Resistor, 47Ω ±5% ¼W
R731	1	1	1	RT05513140	Resistor, 51kΩ ±5% ¼W
R732	1	1	1	RT05513140	Resistor, 51kΩ ±5% ¼W
R733	1	1	1	RT05432140	Resistor, 4.3kΩ ±5% ¼W
R734	1	1	1	RT05432140	Resistor, 4.3kΩ ±5% ¼W
R735	1	1	1	RT05432140	Resistor, 8.2kΩ ±5% ¼W
R736	1	1	1	RT05432140	Resistor, 8.2kΩ ±5% ¼W
R737	1	1	1	RT05432140	Resistor, 8.2kΩ ±5% ¼W
R738	1	1	1	RT05332140	Resistor, 3.3kΩ ±5% ¼W
R739	1	1	1	RT05332140	Resistor, 3.3kΩ ±5% ¼W
R740	1	1	1	RT05223140	Resistor, 22kΩ ±5% ¼W
R741	1	1	1	RT05223140	Resistor, 22kΩ ±5% ¼W
R742	1	1	1	RT05154140	Resistor, 150kΩ ±5% ¼W
R743	1	1	1	RT05154140	Resistor, 150kΩ ±5% ¼W
R744	1	1	1	RT05104140	Resistor, 100kΩ ±5% ¼W
R745	1	1	1	RT05104140	Resistor, 100kΩ ±5% ¼W
R746	1	1	1	RT05151140	Resistor, 150Ω ±5% ¼W
R747	1	1	1	RT05151140	Resistor, 150Ω ±5% ¼W
R748	1	1	1	RT05151140	Resistor, 150Ω ±5% ¼W
R749	1	1	1	RT05201140	Resistor, 200Ω ±5% ¼W
R750	1	1	1	RT05201140	Resistor, 200Ω ±5% ¼W
R751	1	1	1	RT05201140	Resistor, 200Ω ±5% ¼W
R752	1	1	1	RT05201140	Resistor, 200Ω ±5% ¼W

- (U) for U.S.A.
- (C) for Canada
- (N) for Europe

REF. DESIG.	Q'TY			PART NO.	DESCRIPTION			
	U	C	N					
R753	1	1	1	RT05301140	Resistor,	300Ω	±5%	¼W
R754	1	1	1	RT05301140	Resistor,	300Ω	±5%	¼W
R755	1	1	1	RT05301140	Resistor,	300Ω	±5%	¼W
R756	1	1	1	RT05301140	Resistor,	300Ω	±5%	¼W
R757	1	1	1	GF05101140	Resistor,	100Ω	±5%	¼W
R758	1	1	1	GF05101140	Resistor,	100Ω	±5%	¼W
R759	1	1	1	GF05101140	Resistor,	100Ω	±5%	¼W
R760	1	1	1	GF05101140	Resistor,	100Ω	±5%	¼W
R761	1	1	1	GF05101120	Resistor,	100Ω	±5%	¼W
R762	1	1	1	GF05101120	Resistor,	100Ω	±5%	¼W
R763	1	1	1	GW10472020	Resistor,	0.47Ω	±10%	2W
R764	1	1	1	GW10472020	Resistor,	0.47Ω	±10%	2W
R765	1	1	1	GW10472020	Resistor,	0.47Ω	±10%	2W
R766	1	1	1	GW10472020	Resistor,	0.47Ω	±10%	2W
R767	1	1	1	GJ05100020	Resistor,	10Ω	±5%	2W
R768	1	1	1	GJ05100020	Resistor,	10Ω	±5%	2W
R769	1	1	1	RC10022120	Resistor,	2.2Ω	±10%	½W
R770	1	1	1	RC10022120	Resistor,	2.2Ω	±10%	½W
R771	1	1	1	RA01020010	Trimming Resistor,	1kΩ		
R772	1	1	1	RA01020010	Trimming Resistor,	1kΩ		
R773	1	1	1	GF05101120		100Ω	±5%	¼W
R774	1	1	1	GF05101120		100Ω	±5%	¼W
C801	1	1	1	DK18103510	Ceramic Cap.,	0.01μF	±20%	500V
C802	1	1	1	EA22706310	Electrolytic Cap.,	220μF		63V
C803	1	1	1	EA47602590	Electrolytic Cap.,	47μF		25V
C804	1	1	1	EA10603590	Electrolytic Cap.,	10μF		35V
C805	1	1	1	EA47601690	Electrolytic Cap.,	47μF		16V
C806	1	1	1	EA47605090	Electrolytic Cap.,	470μF		50V
C807	1	1	1	DK17103010	Ceramic Cap.,	0.01μF	±10%	50V
C808	1	1	1	DK17103010	Ceramic Cap.,	0.01μF	±10%	50V
C809	1	1	1	EB68805010	Electrolytic Cap.,	6800μF		50V
C810	1	1	1	EB68805010	Electrolytic Cap.,	6800μF		50V
F801			1	FS10350010	Fuse,	3.5A	MGC	UL
F802			1	FS10050800	Fuse,	500mA	T	SEMKO
F803			1	FS10050800	Fuse,	500mA	T	SEMKO
J801								
J814	14	14	14	YP10001130	Plug			
J815			1	YJ08000170	Jack,			Fuse Socket
J816			1	YJ08000170	Jack,			Fuse Socket
J817			1	YJ08000210	Jack,			Fuse Socket
J818			1	YJ08000210	Jack,			Fuse Socket
J819			1	YJ08000210	Jack,			Fuse Socket
Q801	1	1	1	HD20008030	Diode,			DS133A
Q802	1	1	1	HD20008030	Diode,			DS133A
Q803	1	1	1	HT314072B0	Transistor,			2SC1407 (Q, R)
Q804	1	1	1	HT309452A0	Transistor,			2SC945 (Q, R)
Q805	1	1	1	HD30024090	Zener,			WZ-120
Q806	1	1	1	HD30024090	Zener,			WZ-120
R801	1	1	1	GF05101120	Resistor,	100Ω	±5%	¼W
R802	1	1	1	RT05472140	Resistor,	4.7kΩ	±5%	¼W
R803	1	1	1	RT05102140	Resistor,	1kΩ	±5%	¼W
R804	1	1	1	RT05103140	Resistor,	10kΩ	±5%	¼W
R805	1	1	1	RT05103140	Resistor,	10kΩ	±5%	¼W
R806	1	1	1	RT05522140	Resistor,	5.2kΩ	±5%	¼W
R807	1	1	1	GF05472120	Resistor,	4.7kΩ	±5%	¼W

17. TECHNICAL SPECIFICATIONS

FOR U.S.A. MODEL ONLY

AMPLIFIER SECTION

RATED POWER OUTPUT, MINIMUM CONTINUOUS AVERAGE POWER PER CHANNEL, BOTH CHANNELS DRIVEN	45 W
POWER BAND	20 Hz to 20 kHz
TOTAL HARMONIC DISTORTION	0.1%
LOAD IMPEDANCE	8 OHMS
RATED POWER OUTPUT, MINIMUM CONTINUOUS AVERAGE POWER PER CHANNEL, BOTH CHANNELS DRIVEN	57 W
POWER BAND	20 Hz to 20 kHz
TOTAL HARMONIC DISTORTION	0.1%
LOAD IMPEDANCE	4 OHMS

I.M. Distortion

(I.H.F. method, 60 Hz and 7 kHz mixed 4:1 at rated power output)

at 8 ohm load impedance	0.1%
at 4 ohm load impedance	0.1%

Damping Factor (at 20 Hz)

Sensitivity (at MAIN IN)

Impedance (at MAIN IN)

Frequency Response for Power Amp Only

(at 1 watt output, 20 Hz to 20 kHz)

S/N Ratio (MAIN IN)

PREAMPLIFIER SECTION:

Phono

Input overload at 1 kHz

Equivalent Input Noise

Dynamic Range

(Dynamic Range is the ratio of input overload to equivalent input noise)

Input Sensitivity

Input Impedance

Frequency Response, RIAA 20 Hz to 20 kHz

Signal-to-Noise Ratio

(at rated output and 7.75 mV input)

High Level (Aux and Tape)

Input Sensitivity

Input Impedance

Frequency Response

(includes power amp)

Signal-to-Noise Ratio

(ref. to rated output and 775 mV input)

Output Levels

Tape Out (ref. 7.75 mV at Phono inputs)

Pre-Out (ref. 180 mV at Aux inputs)

(ref. 500 mV at Aux inputs, main amp disconnected)

Output Impedance

Tape Out

Pre-Out

GENERAL:

Power Requirements

Dimensions:

Panel Width

Panel Height

Depth

Weight:

Unit alone

Packed for shipment

FOR EUROPEAN MODEL ONLY

AUDIO SECTION

POWER OUTPUT AT 1% DISTORTION	77 W
RATED POWER OUTPUT, 1 kHz	62 W
TOTAL HARMONIC DISTORTION AT RATED POWER OUTPUT, 1 kHz	0.1%
I.M. DISTORTION AT RATED POWER OUTPUT	
(I.H.F. METHOD, 300 Hz AND 10 kHz MIXED 4:1 AT RATED POWER OUTPUT)	0.1%
POWER BANDWIDTH, 1/2 RATED POWER OUTPUT	10 Hz ~ 30 kHz
LOAD IMPEDANCE	4 OHMS
POWER OUTPUT AT 1% DISTORTION	67 W
RATED POWER OUTPUT, 1 kHz	50 W
TOTAL HARMONIC DISTORTION AT RATED POWER OUTPUT, 1 kHz	0.1%
I.M. DISTORTION AT RATED POWER OUTPUT	
(I.H.F. METHOD, 300 Hz AND 10 kHz MIXED 4:1 AT RATED POWER OUTPUT)	0.1%
POWER BANDWIDTH, 1/2 RATED POWER OUTPUT	10 Hz ~ 70 kHz
LOAD IMPEDANCE	8 OHMS

Damping Factor, SP Output	
40 Hz	35
1 kHz	35
12.5 kHz	30
Frequency Response	
Phono ±2 dB	±1.0 dB
Aux ±1.5 dB	±1.0 dB
Main In ±1.5 dB	±0.5 dB
Signal-to-Noise Ratio, 1 kHz	
Phono	78 dB
Aux	91 dB
Main In	55 dB
Input Sensitivity, 1 kHz (Rated Input Voltage)	
Phono	2.0 mV
Aux	200 mV
Main In	1500 mV
Input Impedance, 1 kHz	
Phono	47k ohms
Aux	20k ohms
Phono Equivalent Input Noise	1.0 µV
Phono Dynamic Range	95 dB
Phono Input Capacitance	100 pF
Channel Balance	
Phono 0 ~ -40 dB	2.5 dB
Aux 40 Hz ~ 16 kHz	2.0 dB
Main In	1.0 dB
Interchannel Crosstalk	
Phono 1 kHz	46 dB
250 Hz ~ 10 kHz	40 dB
Aux 1 kHz	50 dB
250 Hz ~ 10 kHz	33 dB
Tape 1 kHz	45 dB
250 Hz ~ 10 kHz	33 dB
Main In 1 kHz	55 dB
250 Hz ~ 10 kHz	50 dB

Intersource Crosstalk, Worst Point	
1 kHz	45 dB
250 Hz ~ 10 kHz	33 dB
Output Voltage, 1 kHz	
Tape Out	0.2 V
Pre Out	1.5 V
Output Impedance, 1 kHz	
Tape Out	330 ohms
Pre Out	220 ohms
Power Consumption	
Idling	25 W
Rated Power, 1 kHz	220 W

GENERAL:

Power Requirements	220V ~ 50 Hz
(E and N versions are featuring an external voltage selector for use on 110/120/240V. Other version can be converted by a qualified technician to operate on 110/120/240V.)	
Power Consumption at rated output, both channels	
operating	205 W
Idling Power	25 W
Semiconductor Complement	
Transistors	43
Diodes	29
Field Effect Transistors	1
Dimensions	
Panel Width	416 mm (16-3/8 inches)
Panel Height	146 mm (5-3/4 inches)
Depth	301 mm (11-27/32 inches)
Weight	
Unit alone	9.5 kg (20.9 lbs)
Packed for shipment	11.5 kg (25.3 lbs)

178



marantz

MARANTZ CO., INC. · P. O. BOX 577 · CHATSWORTH, CALIFORNIA · 91311

A WHOLLY-OWNED SUBSIDIARY OF SUPERSCOPE INC., CHATSWORTH, CALIFORNIA · 91311